

Dell™ Online Rack UPS 10 kW

User's Guide

DELL10KWOLHVUS, DELL10KWOLHV, DELL10KWOLHVB
DELL10KWEBM



Notes and Warnings



NOTE: A NOTE indicates important information that helps you make better use of your product.



CAUTION: A CAUTION indicates a potentially hazardous situation which, if not avoided, may result in minor or moderate injury or in property damage incidents.



WARNING: A WARNING indicates a potentially hazardous situation which, if not avoided, could result in death or injury.



DANGER: A DANGER indicates an imminently hazardous situation which, if not avoided, will result in death or serious injury.



DANGER: Observe the following instruction to help prevent an imminently hazardous situation which, if not avoided, will result in death or serious injury:

- The UPS contains **LETHAL VOLTAGES**. All repairs and service should be performed by **AUTHORIZED SERVICE PERSONNEL ONLY**. There are **NO USER SERVICEABLE PARTS** inside the UPS or EBM.
- This is Class A Interference Causing Equipment. In a residential environment, this product may cause radio interference, in which case the user may be required to take additional measures.

Information in this document is subject to change without notice.

© 2012 Dell Inc. All rights reserved.

Reproduction in any manner whatsoever without the written permission of Dell Inc. is strictly forbidden.

Trademarks used in this text: *Dell* and the *DELL* logo are trademarks of Dell Inc.; *National Electrical Code* and *NEC* are registered trademarks of National Fire Protection Association, Inc.; ENERGY STAR name is a registered trademark owned by the U.S. Environmental Protection Agency.

Other trademarks and trade names may be used in this document to refer to either the entities claiming the marks and names or their products. Dell Inc. disclaims any proprietary interest in trademarks and trade names other than its own.

Table of Contents

- 1 Introduction 6
 - Finding Information** 8
- 2 Safety Warnings 9
- 3 Installation 12
 - Inspecting the Equipment** 12
 - Unpacking the Cabinet** 14
 - Rackmount Setup** 19
 - Installing the UPS** 25
 - Connecting the EBM to the UPS** 26
 - Installing Remote Emergency Power-off** 26
 - Hardwiring the UPS Input** 28
 - UPS Initial Startup** 32
 - UPS Rear Panels** 34
- 4 Operation 37
 - UPS Startup and Shutdown** 38
 - Starting the UPS 38
 - Starting the UPS on Battery 38
 - UPS Shutdown 39
 - Control Panel Functions** 39
 - Changing the Language** 40
 - Display Functions** 41
 - Startup Screen 41
 - Screen Locked 41

Operating Modes	42
Active Notices and Alarms	44
Battery Operating Status	44
Event Log	45
Measurements	46
Control Screens	47
Identification	48
Settings	48
Transferring the UPS Between Modes	53
Transferring from Normal to Bypass Mode	53
Transferring from Bypass to Normal Mode	54
Setting the Power Strategy	54
Retrieving the Event Log	56
Behavior on Overload	56
Configuring Load Segments	57
Controlling Load Segments Through the Display	58
Configuring Automatic Start Delay	58
Configuring Automatic on Battery Shutdown	59
Configuring Battery Settings	60
Configuring the UPS for an EBM	60
Running Automatic Battery Tests	61
Configuring Automatic Battery Tests	61
Configuring Automatic Restart	61
5 Additional UPS Features	62
RS-232 and USB Communication Ports	62
Dell UPS Network Management Card (Optional)	64
Environmental Monitoring Probe (Optional)	64
Dell MUMC and Dell ULNM Software	65

6	UPS Maintenance	66
	UPS and Battery Care	66
	Transporting the UPS	66
	Recharging and Replacing Batteries	71
	Testing Batteries	78
	Updating the UPS Firmware	78
7	Specifications	79
8	Troubleshooting	84
	Accessing Alarms and Conditions	84
	UPS Status Menu	84
	Event Log Menu	85
	Alarms, Notices, and Events	85
	Silencing the Alarm	92

Introduction

The Dell™ Online Rack uninterruptible power system (UPS) protects your sensitive electronic equipment from basic power problems such as power failures, power sags, power surges, brownouts, and line noise.

Power outages can occur when you least expect them and power quality can be erratic. These power problems have the potential to corrupt critical data, destroy unsaved work sessions, and damage hardware — causing hours of lost productivity and expensive repairs.

With the Dell Online Rack UPS, you can safely eliminate the effects of power disturbances and guard the integrity of your equipment. The UPS provides flexibility to handle an array of network devices makes it the perfect choice to protect your LANs, high density servers, blade chassis, and workstations as well as other electrical equipment. The UPS becomes an ideal solution for cloud applications and a wide range of virtualization implementations when the Dell Multi-UPS Management Console (MUMC) and Dell UPS Local Node Manager (ULNM) are used to manage the UPS.

Figure 1 shows the Dell Online Rack 10 kW UPS.

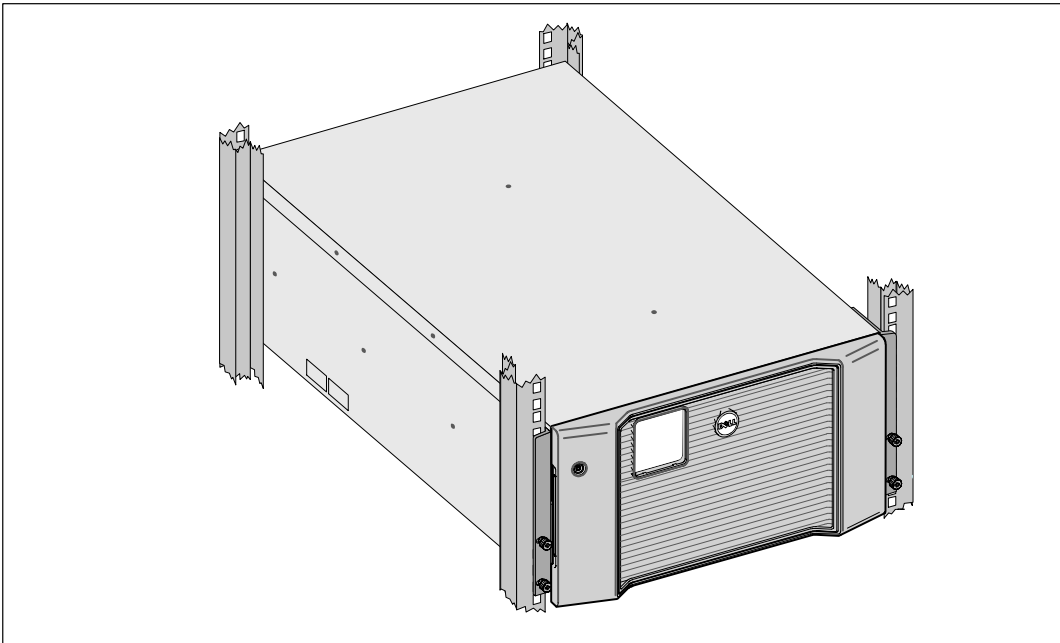

Figure 1. The Dell Online Rack 10 kW UPS

Providing outstanding performance and reliability, the UPS's unique benefits include:

- Online UPS design with pure sine wave output.
- True online double-conversion technology with high power density, utility frequency independence, and generator compatibility.
- Buck and Boost voltage regulation that ensures regulated voltage to your load by correcting voltage fluctuations.
- The UPS filters and regulates incoming AC power and provides consistent power to your equipment without draining the battery.
- Selectable High Efficiency mode of operation.
- 5U UPS height.
- Start-on-battery capability for powering up the UPS even if utility power is not available.
- Maintenance is simplified by allowing the safe replacement of batteries without powering down the UPS.
- Dell service tag information can be read from the front panel LCD display.
- Extended runtime with an optional External Battery Module (EBM).
- Emergency shutdown control through the Remote Emergency Power-off (REPO) ports.
- Two standard communication ports (USB and RS-232 serial port).
- Optional Dell UPS Network Management Card (also known as the NMC) with enhanced communication capabilities for increased power protection and control.
- Optional Environmental Monitoring Probe (EMP) for collecting temperature and humidity readings in the frame environment and monitoring the environmental data remotely. You can also collect and retrieve the status of two user-provided contact devices.
- Advanced power management with the Dell MUMC and Dell ULNM Web-based software applications for graceful shutdowns and power monitoring.
- Sequential shutdown and load management through separate receptacle groups called load segments.
- Firmware that is easily upgradable without a service call.
- Backed by worldwide agency approvals.
- ENERGY STAR[®] certified UPSs.



Finding Information



CAUTION: The *Safety, Environmental, and Regulatory Information* document provides important safety and regulatory information.

What are You Looking For?	Find It Here
<ul style="list-style-type: none">• The user's guide for my UPS• The user's guide for the Dell UPS Network Management Card• Dell MUMC and Dell ULNM User's Guides	<p>Dell UPS Disc</p>  <p>NOTE: Documentation and software updates can be found at www.support.dell.com and at www.dellups.com.</p>
<ul style="list-style-type: none">• Specifications• How to configure UPS settings• How to troubleshoot and solve problems• How to install REPO control	<p>Dell UPS User's Guide</p> <p>The user's guide is available on the Dell UPS disc and on www.support.dell.com.</p>
<ul style="list-style-type: none">• Safety instructions• Regulatory information• Recycling information	<p>Safety, Environmental, and Regulatory Information</p>
<ul style="list-style-type: none">• Warranty information• Terms and Conditions (U.S. only)• End User License Agreement	<p>Dell Warranty and Support Information</p>
<ul style="list-style-type: none">• Support information	<p>Dell Support Website — www.support.dell.com</p> <p>NOTE: Select your region or business segment to view the appropriate support site.</p>

Safety Warnings

 **CAUTION:** Before performing the procedures in this document, read and follow the safety instructions and important regulatory information in your *Safety, Environmental, and Regulatory Information* document.

IMPORTANT SAFETY INSTRUCTIONS SAVE THESE INSTRUCTIONS

This manual contains important instructions that you should follow during installation and maintenance of the UPS and batteries. Please read all instructions before operating the equipment and save this manual for future reference.

 **DANGER:** Observe the following instruction to help prevent an imminently hazardous situation which, if not avoided, will result in death or serious injury:

- The UPS contains **LETHAL VOLTAGES**. All repairs and service should be performed by **AUTHORIZED SERVICE PERSONNEL ONLY**. There are **NO USER SERVICEABLE PARTS** inside the UPS or EBM.

 **WARNING:** Risk of electrical shock. Only qualified service personnel (such as a licensed electrician) shall perform the electrical installation.

 **WARNING:** Observe the following instructions to help prevent a potentially hazardous situation which, if not avoided, could result in death or injury:

- The UPS outputs are protected against overcurrent by circuit breakers.
- This UPS contains its own energy source (batteries). The output receptacles may carry live voltage even when the UPS is not connected to an AC supply.
- To reduce the risk of fire, connect only to a circuit provided with branch circuit overcurrent protection with an ampere rating in accordance with the National Electrical Code[®] (NEC[®]), ANSI/NFPA 70 or your local electrical code:

UPS Output Power	200V	208V	230V
10 kW	63A (Europe) and 80A (North America and Japan)		
	2-pole circuit breaker		

- To reduce the risk of fire or electric shock, install this UPS in a temperature and humidity controlled, indoor environment, free of conductive contaminants. Ambient temperature must not exceed 40°C (104°F). Do not operate near water or excessive humidity (95% maximum).
- Unpacking the cabinet in a low-temperature environment may cause condensation to occur in and on the cabinet. Do not install the cabinet until the inside and outside of the cabinet are absolutely dry (hazard of electric shock).

- If the UPS requires any type of transportation, disconnect the internal UPS batteries before transporting (see page 66).



CAUTION: Observe the following instructions to help prevent a potentially hazardous situation which, if not avoided, may result in minor or moderate injury or in property damage incidents:

- Servicing of batteries should be performed or supervised by personnel knowledgeable about batteries and the required precautions. Keep unauthorized personnel away from batteries.
- Batteries can present a risk of electrical shock or burn from high short-circuit current. The following precautions should be observed: 1) Remove watches, rings, or other metal objects; 2) Use tools with insulated handles; 3) Wear rubber gloves and boots; 4) Do not lay tools or metal parts on top of batteries; 5) Disconnect the charging source prior to connecting or disconnecting battery terminals.
- Determine if the battery is inadvertently grounded. If inadvertently grounded, remove the utility source from the ground. Contact with any part of a grounded battery can result in electrical shock. The likelihood of such shock can be reduced if such grounds are removed during installation and maintenance (applicable to equipment and remote battery supplies not having a grounded supply circuit).
- **ELECTRIC ENERGY HAZARD.** Do not attempt to alter any battery wiring or connectors. Attempting to alter wiring can cause injury.
- Replace batteries with the same number and type of batteries as originally installed in the UPS.
- Proper disposal of batteries is required. Refer to your local codes for disposal requirements.
- Never dispose of batteries in a fire. Batteries may explode when exposed to flame.
- Do not open or mutilate the battery or batteries. Released electrolyte is harmful to the skin and eyes and may be extremely toxic.
- The UPS may be connected to a maximum of one External Battery Module (EBM).



WARNING: Additional instructions for Rack-Mounted Systems:

- Your rack kit has been approved only for the rack cabinet provided. It is your responsibility to ensure that installation of the equipment into any other rack complies with all applicable standards. Dell disclaims all liability and warranties with respect to combinations of equipment with any other rack.
- Before installing your equipment in a rack, install all required stabilizers. Failure to install stabilizers can allow the rack to tip over.
- Always load from the bottom up, and load the heaviest items first.
- Do not overload the AC power supply branch circuit that provides power to the rack.
- Do not stand or step on any components in the rack.
- When installing multiple systems in a rack, complete all of the procedures for the current system before attempting to install the next system.



WARNING: Slide/rail mounted equipment is not to be used as a shelf or work space.



Do not add weight to slide/rail mounted equipment.

Installation

This chapter explains:

- Equipment inspection
- Unpacking the cabinet
- UPS rear panels
- UPS setup and installation, including the External Battery Module (EBM)
- Remote Emergency Power-off (REPO) installation
- Initial startup

 **NOTE:** Discard or recycle the packaging in a responsible manner, or store it for future use.

Inspecting the Equipment

If any equipment has been damaged during shipment, keep the shipping cartons and packing materials for the carrier (see Figure 2) or place of purchase and file a claim for shipping damage. If you discover damage after acceptance, file a claim for concealed damage.

To file a claim for shipping damage or concealed damage: 1) File with the carrier within 15 days of receipt of the equipment; 2) Send a copy of the damage claim within 15 days to your service representative.

 **NOTE:** Check the battery recharge date on the shipping carton label. If the date has passed, do not use the UPS. Contact your service representative.

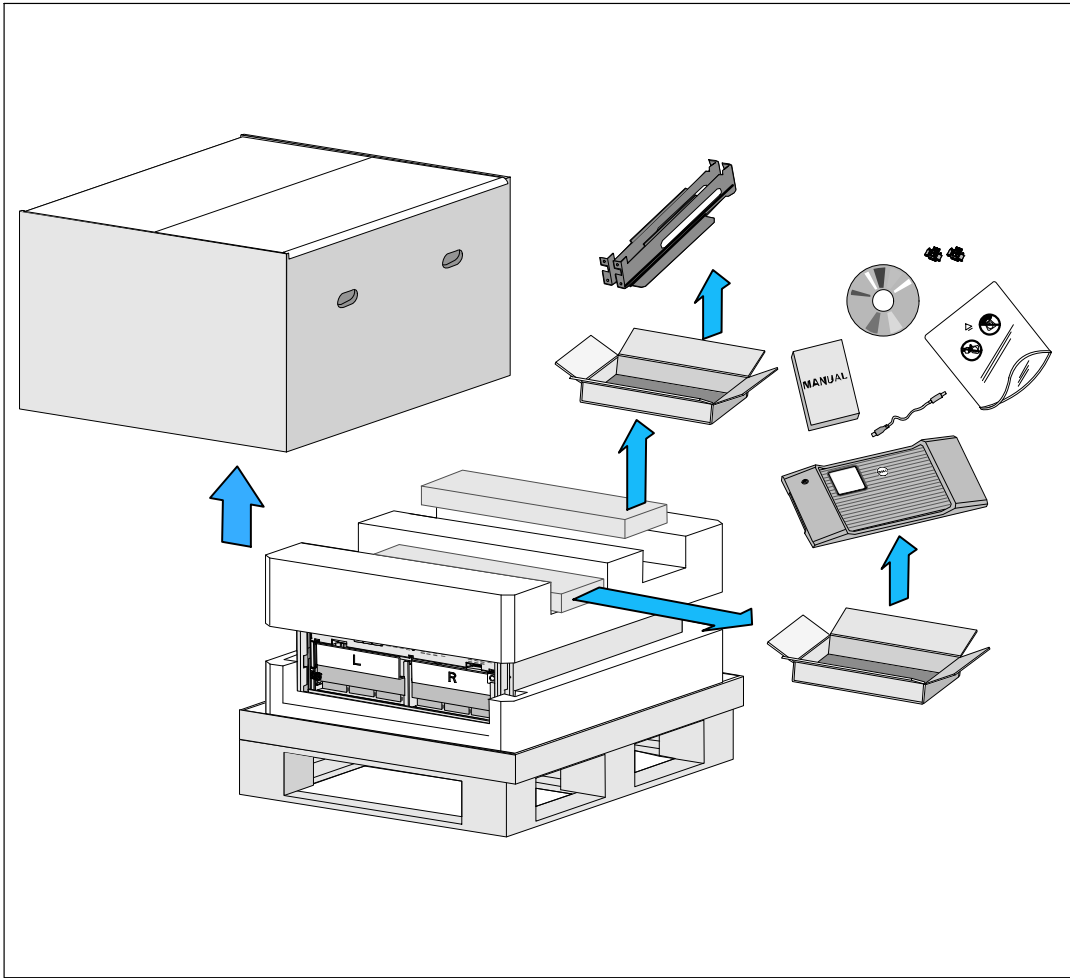







Figure 2. Shipping Carton Contents

Unpacking the Cabinet

-  **CAUTION:** Unpacking the cabinet in a low-temperature environment may cause condensation to occur in and on the cabinet. Do not install the cabinet until the inside and outside of the cabinet are absolutely dry (hazard of electric shock).
-  **CAUTION:** Installing or removing the battery trays should be performed or supervised by personnel knowledgeable about batteries and the required precautions. Keep unauthorized personnel away from batteries.
-  **CAUTION:** The cabinet is heavy (see page 79): Always remove both battery trays from the UPS before lifting the cabinet. Lifting the cabinet into the rack requires a minimum of two people.
-  **CAUTION:** The batteries are heavy (32 kg/71 lb). Use proper lifting techniques when removing the batteries.
-  **NOTE:** Use care when moving and opening the carton. Leave the components packaged until ready to install.

To unpack the system:

- 1 Using a forklift or pallet jack, move the shipping carton and pallet near the rack where you will install the UPS (see Figure 3).

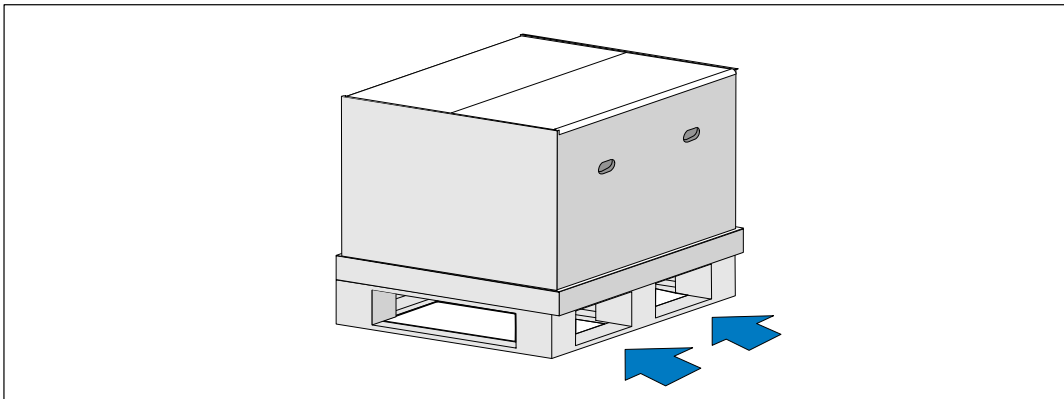

Figure 3. Lifting the Pallet with Shipping Carton

- 2 Detach and remove the outer carton (see Figure 4).

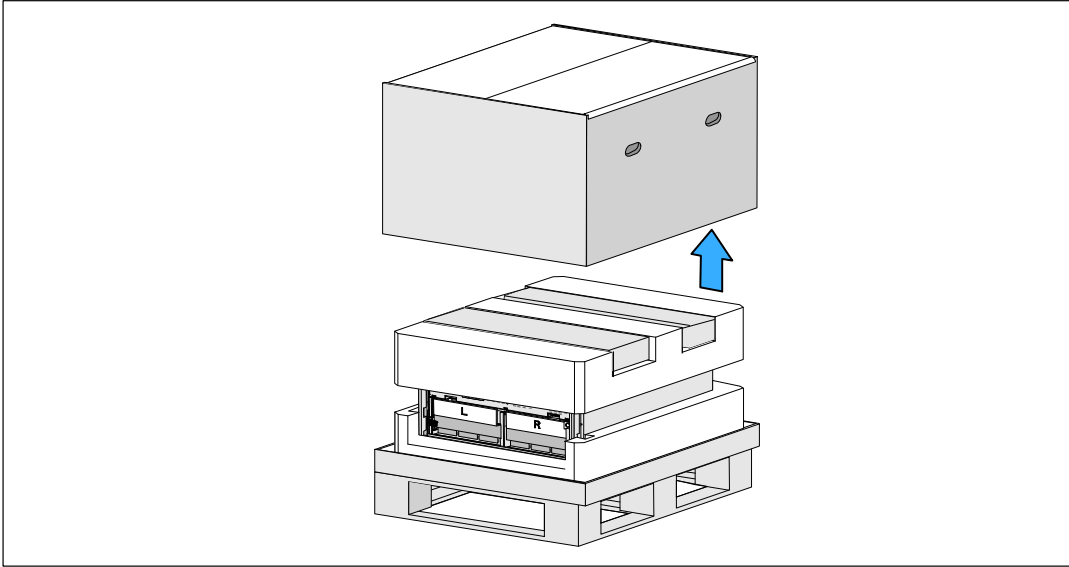

Figure 4. Detaching the Outer Carton

- 3 Remove the two accessory boxes tucked into the channels in the top Styrofoam section. Open the accessory boxes and set them on a flat, stable surface nearby (see Figure 5).



NOTE: The *Dell Online Rack UPS 10 kW Getting Started Guide* provides unpacking and installation procedures. To refer to it, remove it from the accessory box before you set the accessory boxes aside.

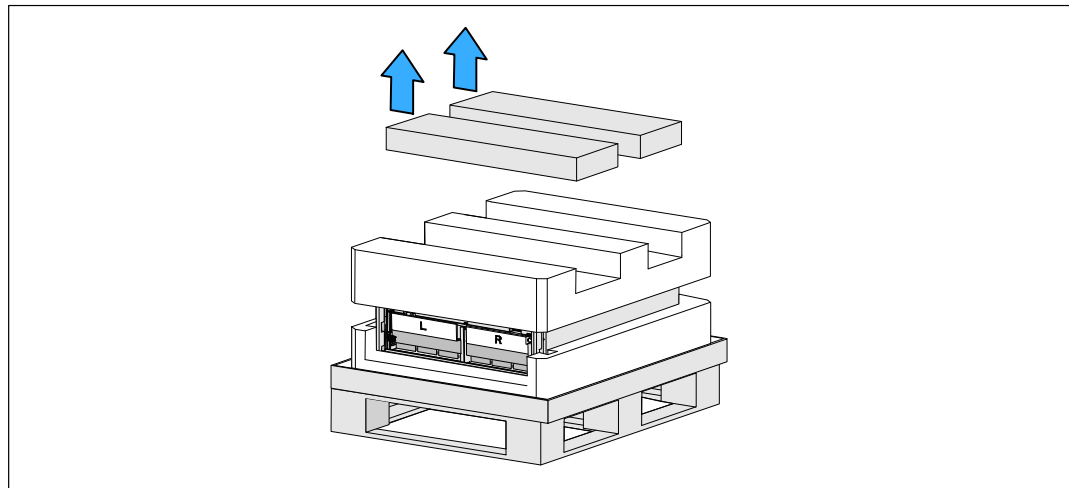

Figure 5. Removing the Accessory Boxes

- 4 Remove the top Styrofoam section and set it on a flat, stable surface nearby (see Figure 6).

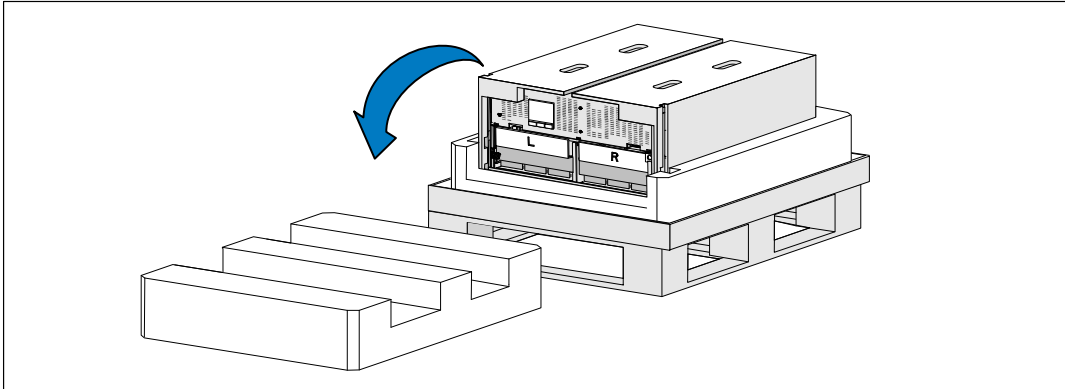



Figure 6. Removing the Top Styrofoam Section

 **NOTE:** The battery retaining brackets are labeled L (left) and R (right) to indicate where they must be installed.

- 5 Remove both battery retaining brackets from the UPS (see Figure 7):

Locate the left (labeled **L**) retaining bracket. On the left side of the chassis, turn the thumbscrew counter-clockwise to release the left retaining bracket.

Push the bracket toward the center post to disengage it from the chassis. Swing the bracket toward you and pull the bracket to the left to remove it. Set the bracket aside.

Locate the right (labeled **R**) retaining bracket. On the right side of the chassis, turn the thumbscrew counter-clockwise to release the right retaining bracket.

Push the bracket toward the center post to disengage it from the chassis. Swing the bracket toward you and pull the bracket to the right to remove it. Set the bracket aside.

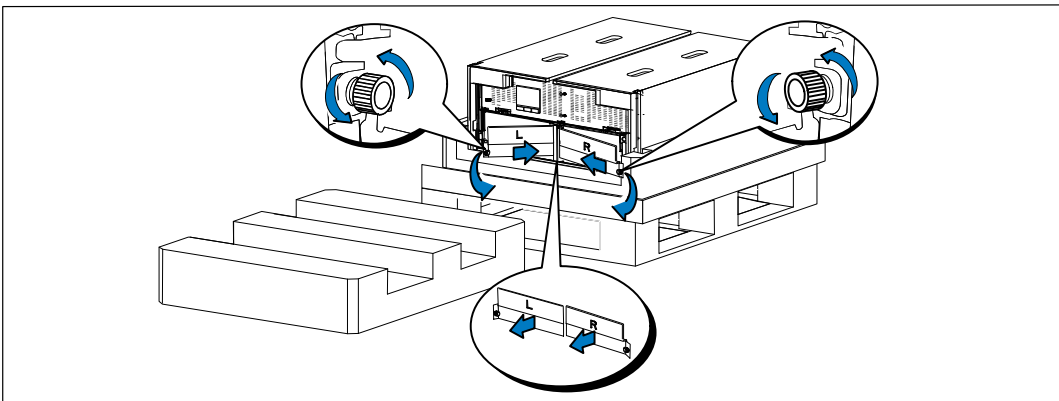

Figure 7. Removing the Battery Retaining Brackets

6 Ensure all battery connectors are disconnected.

⚠ CAUTION: The batteries are heavy (32 kg/71 lb). Use proper lifting techniques when removing the batteries.

7 Remove the battery trays from the UPS (see Figure 8):

Move the disconnected UPS battery connectors at the top of the battery compartment out of the way.

Grip the two plastic loop tabs on the front of the battery tray. Pull the tray toward you to remove.

📌 NOTE: The orange PULL HERE labels indicate where to grasp the loop tabs.

Set the battery tray on the Styrofoam section you removed from the top of the UPS.

Repeat with the second battery tray.

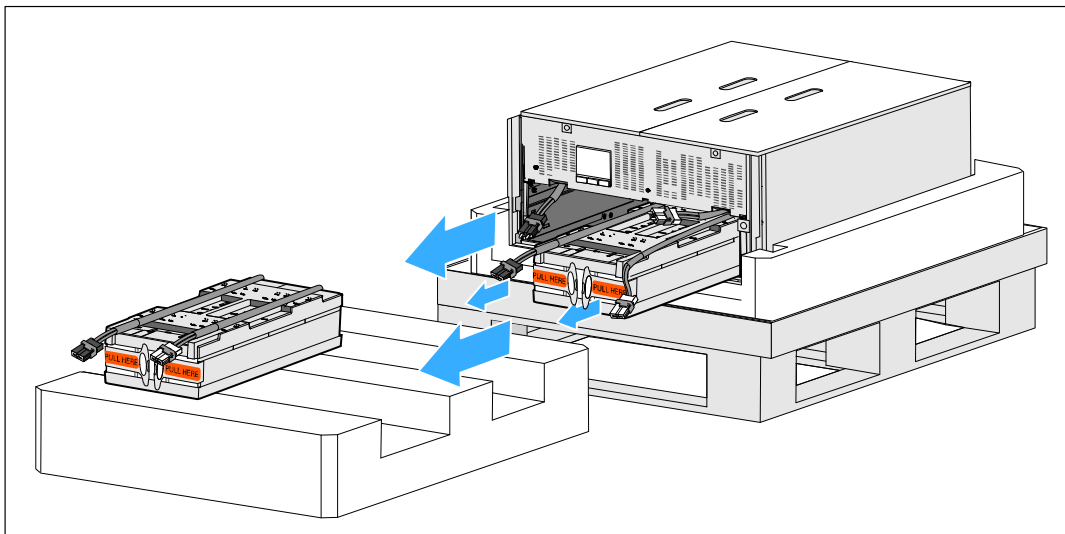

Figure 8. Removing the Battery Trays

⚠ CAUTION: The cabinet is heavy (46 kg/101 lb) with the batteries removed. Lifting the cabinet from the shipping carton requires a minimum of two people.

8 With one person on each side, carefully lift the cabinet out of the styrofoam using the handles on the cardboard (see Figure 9).

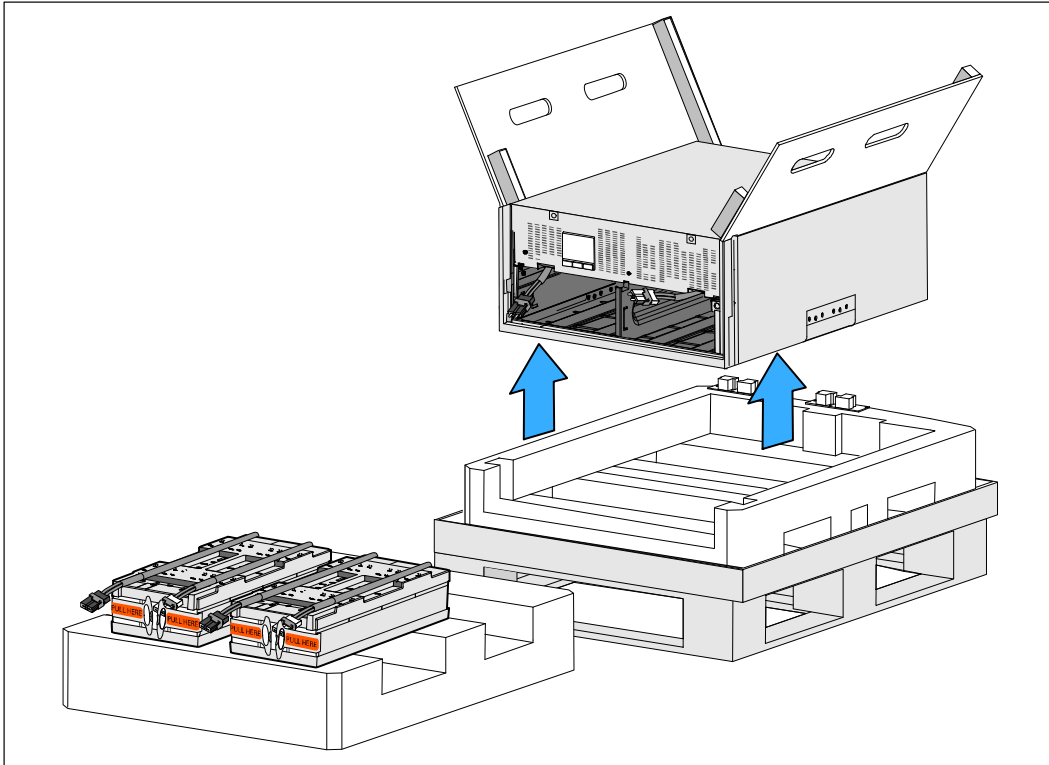









Figure 9. Lifting the Cabinet

9 Place the cabinet on a flat, stable surface in a protected area near the rack where you will install it.

📌 NOTE: Ensure that the area has adequate airflow and is free of humidity, flammable gas, and corrosion.

Rackmount Setup

-  **CAUTION:** The cabinet is heavy (see page 79): Always remove both battery trays from the UPS before lifting the cabinet and installing the UPS on the rails in the rack. Lifting the cabinet into the rack requires a minimum of two people.
-  **CAUTION:** Installing or removing the batteries should be performed or supervised by personnel knowledgeable about batteries and the required precautions. Keep unauthorized personnel away from batteries.
-  **CAUTION:** The batteries are heavy (32 kg/71 lb). Use proper lifting techniques when removing the batteries.
-  **CAUTION:** If installing an optional EBM, the EBM must be located below the UPS with no U space between the UPS and EBM. This provides better weight distribution in the rack, easier access to the UPS control panel, and easier routing for the battery cable connections. This also prevents strain between the EBM cord and the UPS connection and possible connection failure.
-  **WARNING:** For Rack-Mounted Systems: When installing multiple systems in a rack, complete all of the procedures for the current system before attempting to install the next system.
-  **NOTE:** Mounting rails are required for each individual cabinet.
-  **NOTE:** The cabinet is shipped without the front cover attached.
-  **NOTE:** The following instructions are the same for square-hole racks and unthreaded, round-hole racks. The rails fit both rack styles.

To install the UPS in a rack:

- 1 Ensure that the following are placed on a flat, stable surface near the rack where you will install the UPS:
 - cabinet
 - two accessory boxes
 - two battery trays (UPS only)
 - two battery retaining brackets (UPS only)
- 2 Remove the rails from the rail kit accessory box.
- 3 Select the proper holes in the rail for positioning the cabinet in the desired location in the rack.
Locate the rails at the bottom of the 5U space allocated for the UPS.



CAUTION: If installing an optional EBM, make provision for installing the EBM directly below the UPS with no U space between the UPS and EBM.

4 Position the left and right rails as illustrated (see Figure 10).



NOTE: Observe the labels on the rails for right front (labeled RIGHT FRONT) and left front (labeled LEFT FRONT).

5 Attach the left and right rails to the rack:

Engage the back end of the rail until it fully seats on the vertical rack flange and the hook latch locks in place (see Figure 10).

Pull the rail just past the front of the rack.

Push the front end of the rail until it fully seats on the vertical rack flange and the hook latch locks in place.

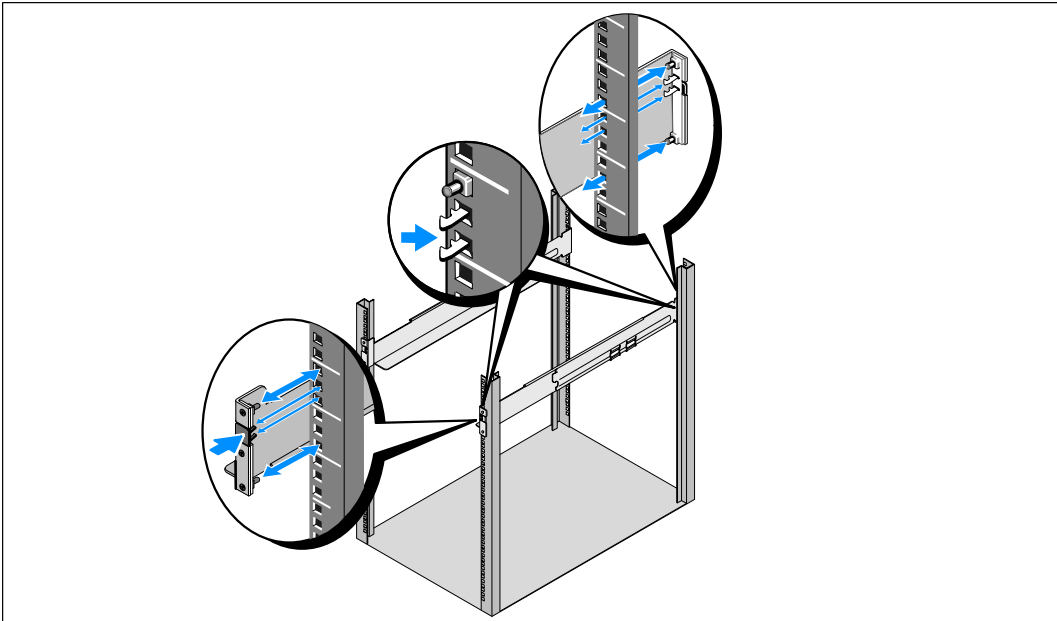

Figure 10. Installing the Rails



CAUTION: The cabinet is heavy (46 kg/101 lb) with the batteries removed. Lifting the cabinet into the rack requires a minimum of two people.

- 6 Slide the cabinet onto the rails and into the rack (see Figure 11).

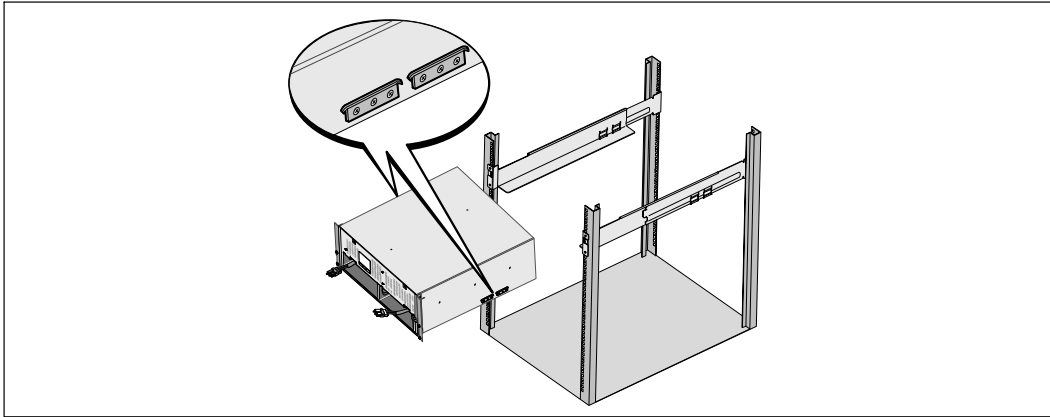

Figure 11. Installing the Cabinet

- 7 Secure the front of the cabinet to the rack using the four thumbscrews on the mounting brackets (see Figure 12). Tighten the thumbscrews clockwise by hand; do not use power tools.

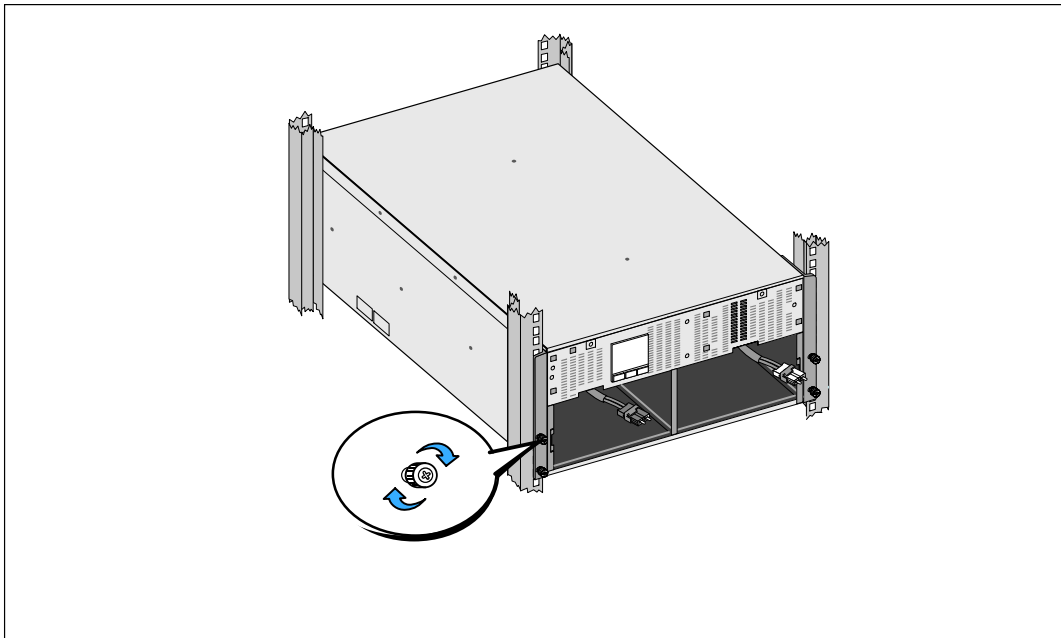

Figure 12. Securing the Cabinet

8 Locate the battery trays you placed near the rack.



CAUTION: The batteries are heavy (32 kg/71 lb). Use proper lifting techniques when installing the batteries.



NOTE: The battery trays can be installed in either battery compartment.



NOTE: Insert the tray with the caution label arrow pointing upward.

9 Install the battery trays (see Figure 13):

Move the UPS battery connectors at the top of the battery compartment out of the way.

Slide the battery tray into the battery compartment completely.

Repeat to install the second battery tray.

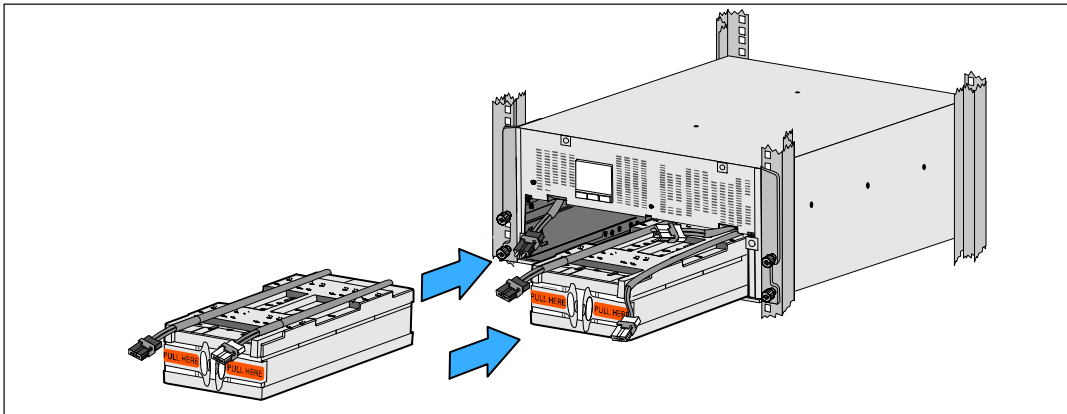

Figure 13. Installing the Battery Trays

10 Tuck the loop tabs into the plastic sleeve on the front of each battery tray to move them out of the way.

11 Connect the internal battery connectors (see Figure 14):

Connect the far-left battery tray connector to the UPS battery connector. Connect the far-right battery tray connector to the UPS battery connector.



NOTE: A small amount of arcing may occur when connecting the batteries. This is normal and does not damage the unit or present any safety concerns.

Locate and connect the battery jumpers located on either side of the center post. Place the connectors on the small shelf at the top of the center post.



NOTE: Connecting the center battery jumpers connects the two battery trays serially.

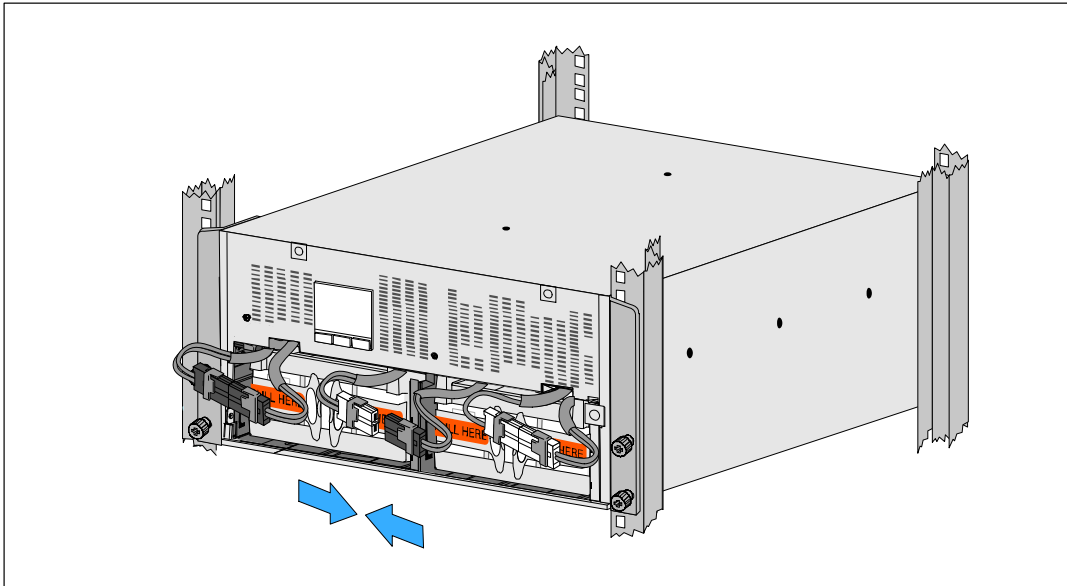

Figure 14. Connecting the Battery Connectors

NOTE: The battery retaining brackets are labeled L (Left) and R (Right) to indicate where they must be installed.

12 Replace the left (L) and right (R) battery retaining brackets (see Figure 15):

For the first battery retaining bracket, insert the bracket tab into the channel on the side of the center post. Fit the connected battery cables snugly behind the retaining bracket.

Align the end of the battery retaining bracket with the channel on the side of the chassis.

Push the bracket until it is firmly seated into the side channel.

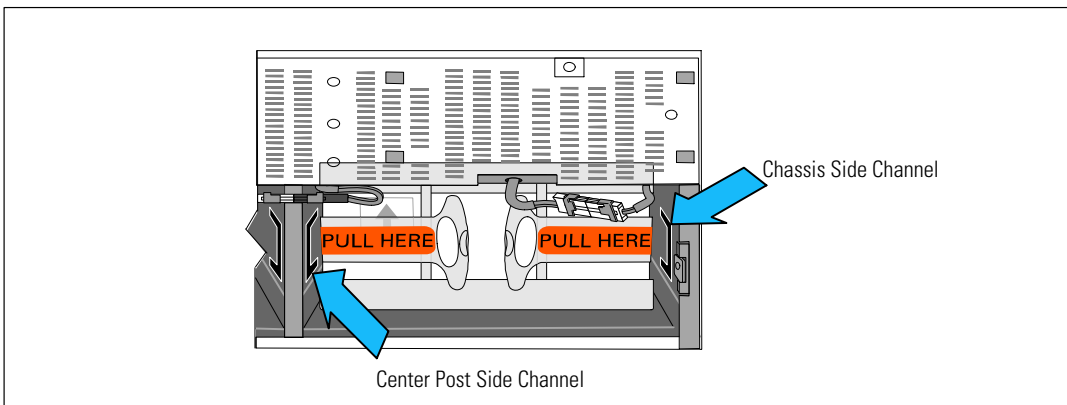



Figure 15. Inserting the bracket into the Channels

Turn the thumbscrew clockwise to secure the bracket.

Repeat to replace the second battery retaining bracket.

- 13 Remove the front cover from the accessory box (see Figure 16).

 **NOTE:** Keep the software CD, communication cable, and (if needed) remote emergency power-off (REPO) connectors in the accessory box until you install the UPS (see page 25).

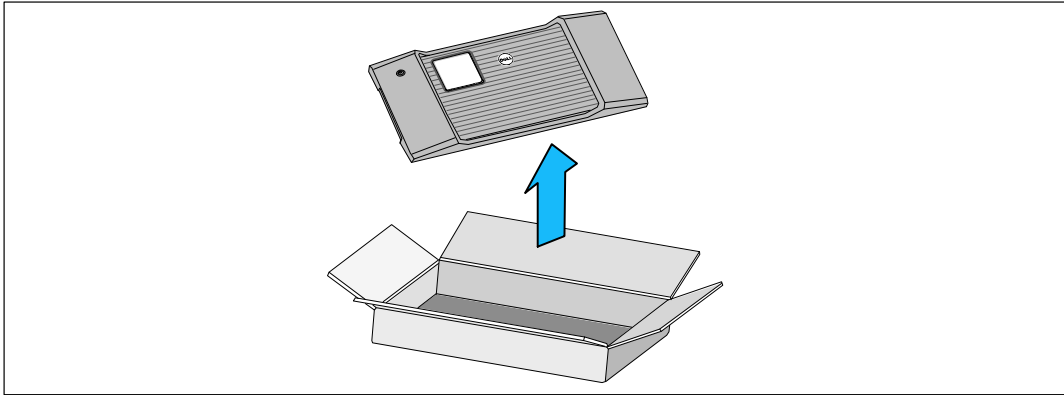



Figure 16. Unpacking the Front Cover

- 14 Install the front cover (see Figure 17):

Align the front cover with the front of the chassis.

Insert the right-side tabs on the front cover into tab openings on the right-side chassis.

Push the left side of the cover forward and snap it to the chassis.

 **NOTE:** Ensure that the LCD panel on the UPS chassis aligns with the LCD window on the front cover before securing the cover to the chassis.

- 15 Discard or recycle the packaging in a responsible manner, or store it for future use.

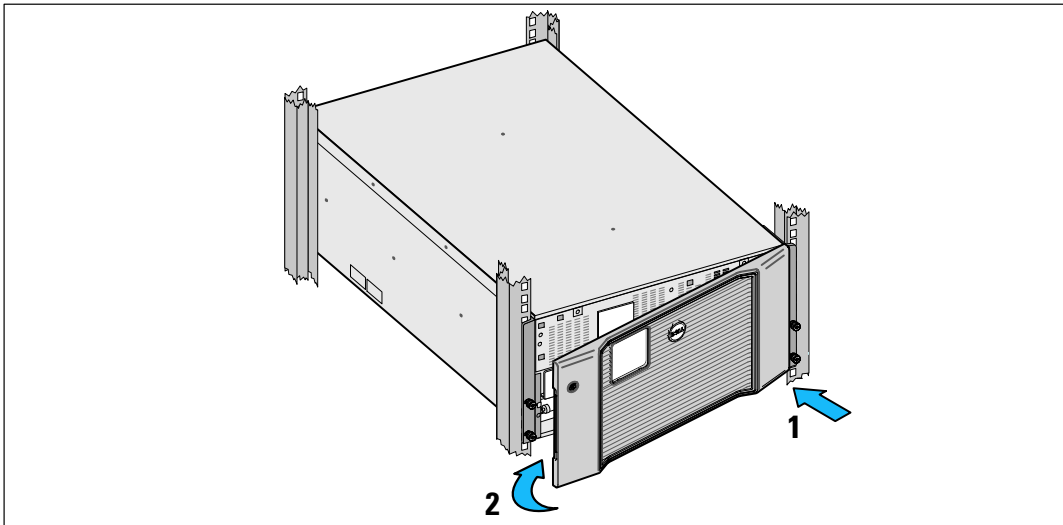

Figure 17. Installing the Front Cover

Installing the UPS

To install the UPS:

- 1** If you plan to use Dell MUMC and Dell ULNM software, establish communication in one of the following ways:
 - using the Dell UPS Network Management Card (if installed)
 - using the supplied cable to connect your computer to the USB port

For more information about communication options, see page 62.

- 2** If your rack has conductors for grounding or bonding of ungrounded metal parts, connect the ground cable (not supplied) to the ground bonding screw. See “UPS Rear Panels” on page 34 for the location of the ground bonding screw for each model.
- 3** If an emergency power-off (disconnect) switch is required by local codes, see the following section, “Installing Remote Emergency Power-off” to install the emergency disconnect switch before powering on the UPS. See “UPS Rear Panels” on page 34 for the location of the REPO connector for each model.
- 4** Plug the equipment to be protected into the UPS output receptacles, but do not turn on the protected equipment.
- 5** Make any necessary provisions for cord retention and strain relief.



NOTE: Verify that the total equipment ratings do not exceed the UPS capacity to prevent an overload alarm.

Connecting the EBM to the UPS

If you are installing an optional EBM, refer to the *Dell Online Rack EBM 10 kW Getting Started Guide* for installation instructions.



CAUTION: If installing an optional EBM, the EBM must be located below the UPS with no U space between the UPS and EBM. This provides better weight distribution in the rack, easier access to the UPS control panel, and easier routing for the battery cable connections. This also prevents strain between the EBM cord and the UPS connection and possible connection failure.



CAUTION: If the UPS is stored or used without an EBM, the battery connector cover on the rear panel of the UPS must be installed as a safety precaution.



CAUTION: When connected to the UPS, the EBM will continue to supply power to the UPS, even if the UPS batteries are disconnected. This is particularly important if the EBM and UPS will be transported while installed in a rack enclosure.

Installing Remote Emergency Power-off

The UPS includes a REPO connector that enables you to turn off power at the UPS output receptacles from a customer-supplied switch in a remote location. For example, this feature can be used for shutting down the load and the UPS by thermal relay, in the event of room overtemperature. When REPO is activated, the UPS shuts down the output and all its power converters immediately. The UPS logic power remains on to issue an alarm.

The REPO feature shuts down the protected equipment immediately and does not follow the orderly shutdown procedure initiated by any power management software. Any devices that are operating on battery power are also shut down immediately.

When the REPO switch is reset, the equipment will not return to utility or battery power until the UPS is manually restarted.

The REPO contacts are normally open.



WARNING: The REPO circuit is an IEC 60950 safety extra low voltage (SELV) circuit. This circuit must be separated from any hazardous voltage circuits by reinforced insulation.



CAUTION: The REPO must not be connected to any utility connected circuits. Reinforced insulation to the utility is required. The REPO switch must have a minimum rating of 24 Vdc and 20 mA and be a dedicated latching-type switch not tied into any other circuit. The REPO signal must remain active for at least 250 ms for proper operation.



CAUTION: To ensure the UPS stops supplying power to the load during any mode of operation, the input power must be disconnected from the UPS when the emergency power-off function is activated.

NOTE: For Europe, the emergency switch requirements are detailed in Harmonized document HD-384-48 S1, “Electrical Installation of the Buildings, Part 4: Protection for Safety, Chapter 46: Isolation and Switching.”

REPO Connections

Wire Function	Terminal Wire Size Rating	Suggested Wire Size
REPO	4–0.32 mm ² (12–22 AWG)	0.82 mm ² (18 AWG)

NOTE: The pins must be open to keep the UPS running. If the UPS shuts down because the REPO connector pins are shorted, restart the UPS by re-opening the REPO connector pins and turning on the UPS manually. Maximum resistance in the shorted loop is 10 ohm.

NOTE: Always test the REPO function before applying your critical load to avoid accidental load loss.

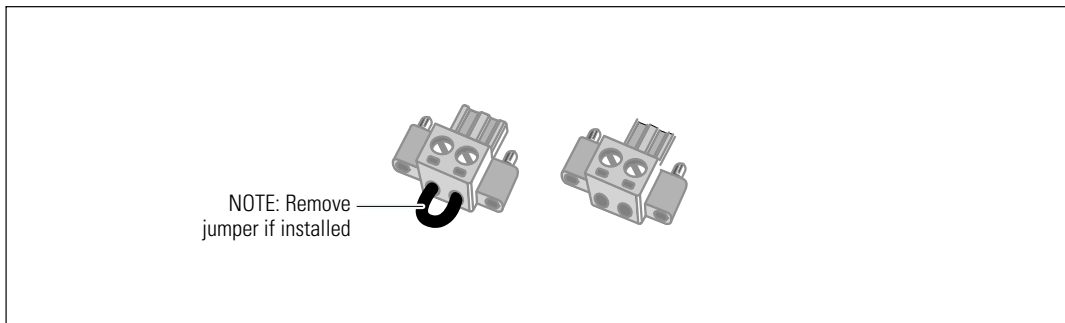

Figure 18. REPO Connector

To install the REPO switch:

- 1 Verify that the UPS is off and disconnected from utility power.
- 2 Remove the REPO connectors from the accessory box.

NOTE: Verify that there is no jumper installed in the REPO connector. If a jumper is installed, remove it before connecting to the REPO port. See Figure 18.

- 3 Connect the REPO connector to the REPO port labeled IN on the UPS rear panel.

CAUTION: If you are daisy-chaining the REPO function, observe the following connection requirements to avoid unintentional shutdown of the UPS:

- The left pin of the REPO port labeled OUT on the first UPS must be connected to the left pin of the REPO port labeled IN on the second UPS.
- The right pin of the REPO port labeled OUT on the first UPS must be connected to the right pin of the REPO port labeled IN on the second UPS.

- 4 Optional.** If you are daisy-chaining the REPO function with another UPS, you can shut down the entire system using a single switch.

Connect the second REPO connector to the REPO port labeled **OUT**.



NOTE: A separate contact must simultaneously cause UPS input AC power to be removed.

- 5** Connect the switch or circuit to the REPO connector on the UPS rear panel using insulated 0.75 mm²–0.5 mm² (18–20 AWG) wire.
- 6 Optional.** If you are daisy-chaining the REPO function with another UPS, connect the REPO port labeled **OUT** to the REPO port labeled **IN** on the next UPS.

Continue for each UPS. On the last UPS in the daisy-chain, connect a REPO connector (without a jumper) in the REPO port labeled **OUT**.

- 7** Verify that the externally-connected REPO switch is not activated to enable power to the UPS output receptacles.
- 8** Continue to the following section, “Hardwiring the UPS Input.”

Hardwiring the UPS Input



WARNING: Risk of electrical shock. Only qualified service personnel (such as a licensed electrician) shall perform the electrical installation.

The Dell Online Rack hardwired models require a dedicated branch circuit that meets the following requirements:

- Protection device requires a two-pole disconnection device between the UPS input and the mains (see Figure 19)
- Breaker must be wall-mounted and be readily accessible to the operator
- **For Europe.** Breaker must meet the IEC/EN 60934 standard and have a contact air gap of at least 3 mm
- 200–240 Vac
- Single-phase
- 50/60 Hz
- Flexible metal conduit (recommended for ease of service and maintenance)

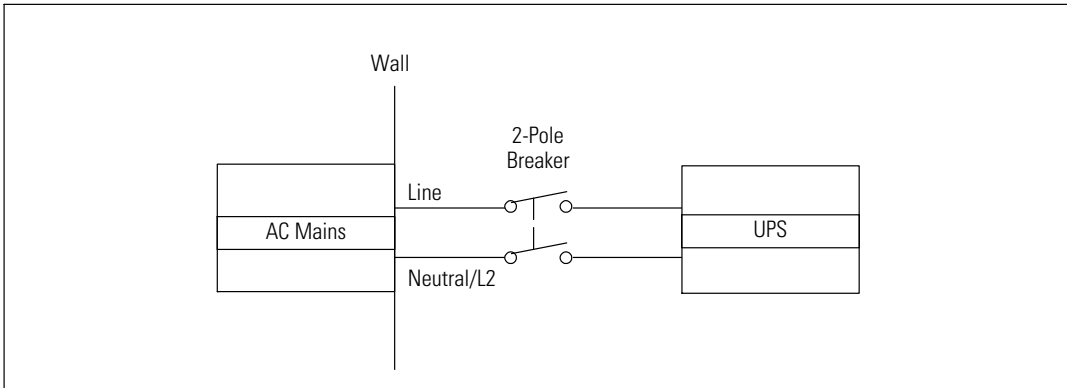

Figure 19. Circuit Breaker Diagram

To hardwire the UPS input:

- 1** Switch off utility power at the distribution point where the UPS will be connected. Be absolutely sure there is no power.
- 2** Remove the terminal block cover (two screws) and retain.

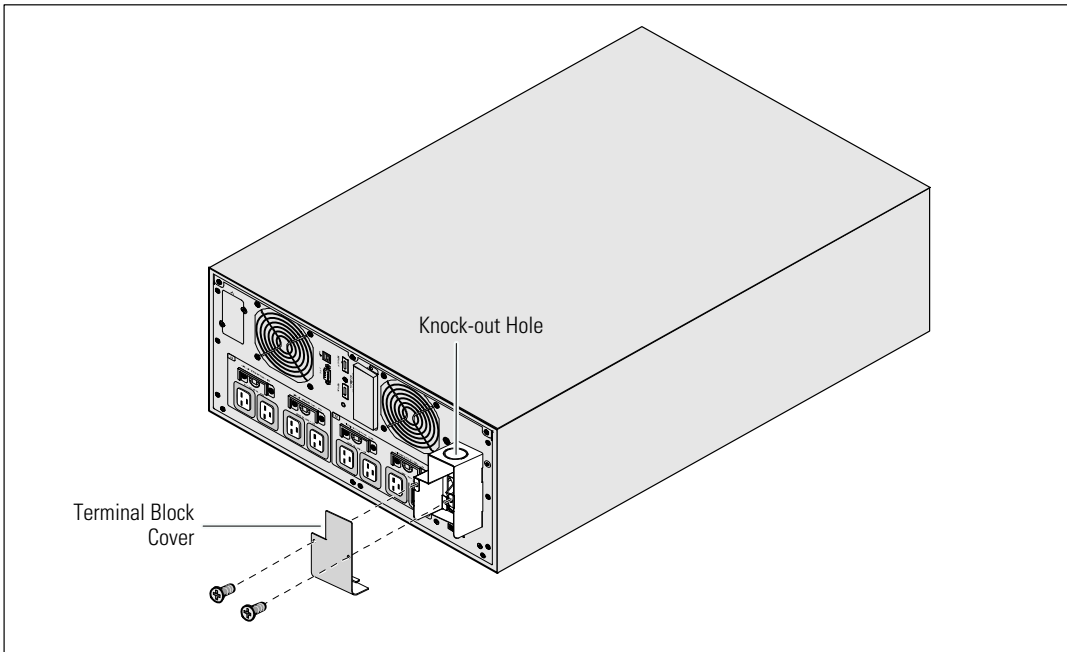

Figure 20. Removing the Terminal Block Cover

- 3 Remove the knock-out hole in the terminal block cover for the input conduit. The hole must accommodate 1" or 1.5" (25.4 mm or 38.1 mm) Intermediate Metal Conduit (IMC).
- 4 Pull the input wire through the conduit, leaving approximately 2 ft (0.5m) of exposed wire. Attach a flexible metal fitting to the end of the conduit.
- 5 Insert the conduit through the wiring access entry and attach the conduit fitting to the panel. Strip 0.5" (1.5 cm) of insulation from the end of each incoming wire.



CAUTION: If the UPS does not have an automatic protection device against current backfeed, install an external isolating device (see Figure 21). After the device is installed, you must add a warning label with the following wording or the equivalent on the external AC contactor: RISK OF VOLTAGE BACKFEED. Isolate the UPS before operating on this circuit, then check for hazardous voltage between all terminals.

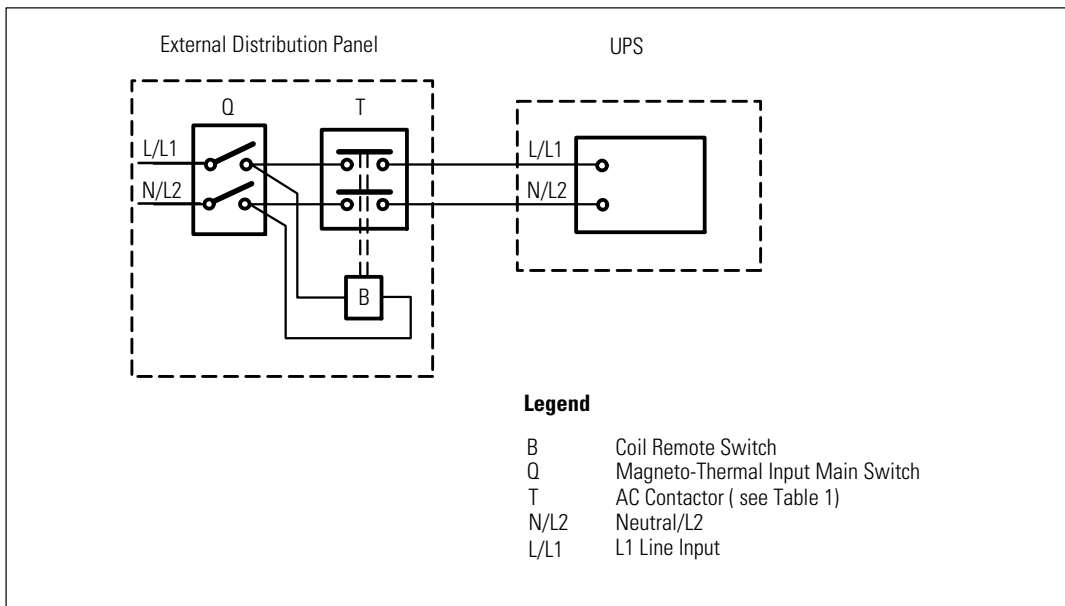

Figure 21. Typical External Isolating Device Installation

The following table lists backfeed protection devices (AC contactors) that can be used as an external isolating device for backfeed protection. Only use AC contactors listed in the table.

Table 1. Backfeed Protection Devices

Manufacturer	Type	Rating
ABB France (E12527)	A75-30	220–240 Vac, 105A 25 HP at 208V, 30HP at 240V
Tianshui 213 Electrical Apparatus Co., Ltd. (E203071) (alternative)	GSC1(CJX4-d)-6511	220–240 Vac, 68A 25 HP
Tianshui 213 Electrical Apparatus Co., Ltd. (E203071) (alternative)	GSC1(CJX4-d)-8011	220–240 Vac, 80A 30 HP

NOTE: Although the UPS does not contain anti-backfeed (ABF) relays, some backfeed protection is provided. For example, if some components are damaged in battery mode, the output voltage may feed back to the input. In this case, a current transformer (CT) is used to detect the bypass current feedback voltage. If a current backfeed fault condition is detected, the UPS will terminate the inverter output to avoid the personal injury.

6 Connect the input and ground wires to the terminal block according to Figure 22 and Table 2.

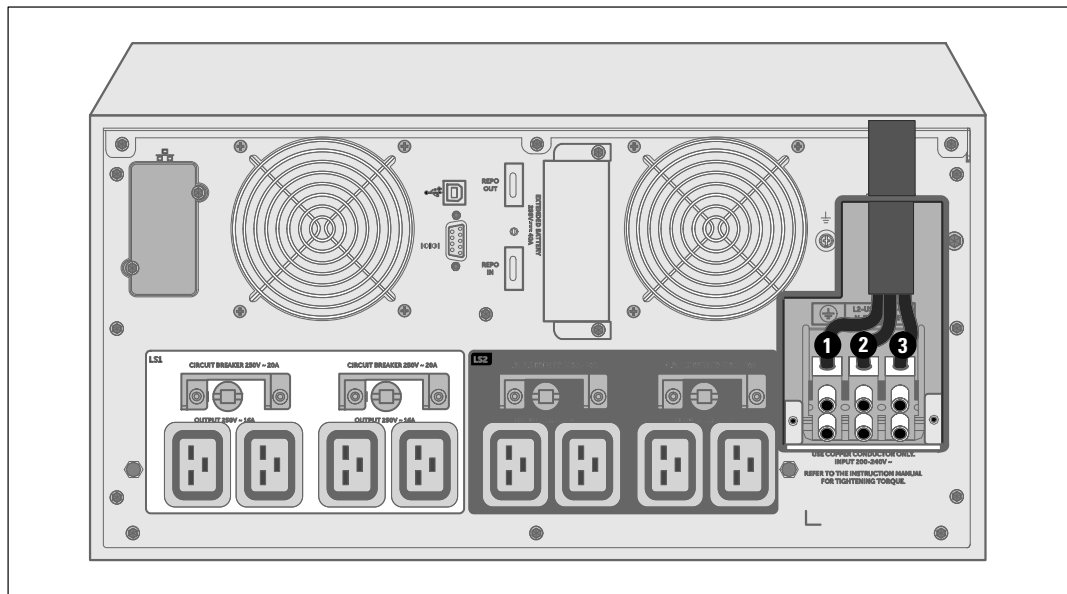

Figure 22. Connecting Terminal Block Wiring

Table 2. UPS Wiring Specifications

Wire Function	Terminal Position	UPS Wire Function	Terminal Wire Size Rating*	Tightening Torque
Input	①	Input Ground	16–35 mm ² (8–2 AWG)	1.7 Nm (15 lb-in)
	②	L2/Neutral In		
	③	L1 In		

* Use a minimum:

- 10 mm² (8 AWG) for equipment grounding wire, 75°C copper wire minimum
- 25 mm² (4 AWG) for input line and neutral wires, 75°C copper wire minimum

- 7 Replace the terminal block cover.
- 8 Continue to the following section, “UPS Initial Startup.”

UPS Initial Startup

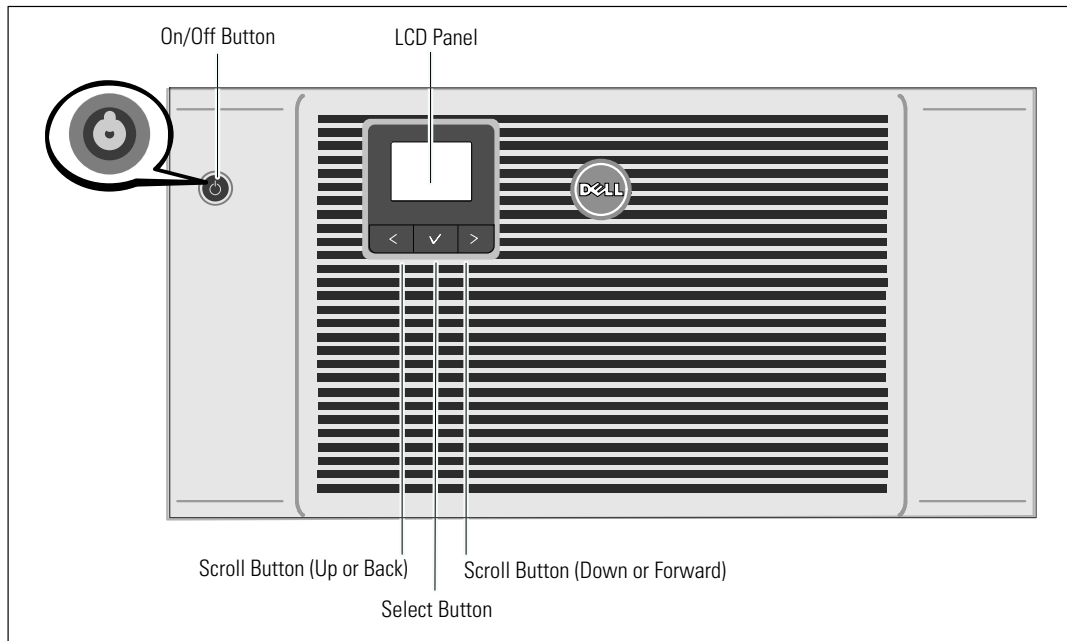



Figure 23. Starting the UPS

To start up the UPS:

- 1 Verify that the internal batteries are connected.
- 2 If an optional EBM is installed, verify that the EBM is connected to the UPS. Refer to the *Dell Online Rack EBM 10 kW Getting Started Guide* for more information.
- 3 Verify that all load segment circuit breakers are in the ON position.
- 4 Switch the main utility breaker on.

The UPS LCD panel display illuminates. The Dell startup screen changes to the UPS status summary screen. The UPS front panel display shows the flashing Standby icon .

- 5 Press the On/Off  button on the UPS front panel (see Figure 23).

After the startup is complete, the status icon changes to the appropriate icon based on the UPS operating mode (see Table 4 on page 42).

- 6 On the UPS status control panel, press the  button to check for active alarms or notices. Resolve any active alarms before continuing. See “Troubleshooting” on page 84.

If there are no active alarms, a “No Active Alarms” message appears.

- 7 Verify that the Normal icon  appears on the UPS status summary screen, indicating that the UPS is operating normally and any loads are powered (see Table 4 on page 42).

- 8 If an optional EBM is installed, see “Configuring the UPS for an EBM” on page 60.

- 9 To change other factory-set defaults, see “Operation” on page 37.

- 10 If you installed an optional REPO, test the REPO function:

Activate the external REPO switch. Verify the status change on the UPS display.

Deactivate the external REPO switch and restart the UPS.

- 11 Charge the batteries.



NOTE: The internal batteries charge to 90% capacity in less than 4 hours. However, Dell recommends that the batteries charge for 48 hours after installation or long-term storage.



CAUTION: To prevent an UPS overload condition, connect one load at a time and make sure that each protected device starts up completely before you connect the next load.



NOTE: Dell recommends setting the date and time for troubleshooting or warranty purposes.



NOTE: At initial startup, the UPS sets system frequency according to input line frequency (input frequency auto-sensing is enabled by default). After initial startup, auto-sensing is disabled until manually re-enabled by output frequency setting.



NOTE: At initial startup, input voltage auto-sensing is enabled by default. After the subsequent startup, auto-sensing is disabled until manually re-enabled by output voltage setting.

UPS Rear Panels

This section illustrates the rear panels of the three Dell Online Rack 10 kW UPS model options.

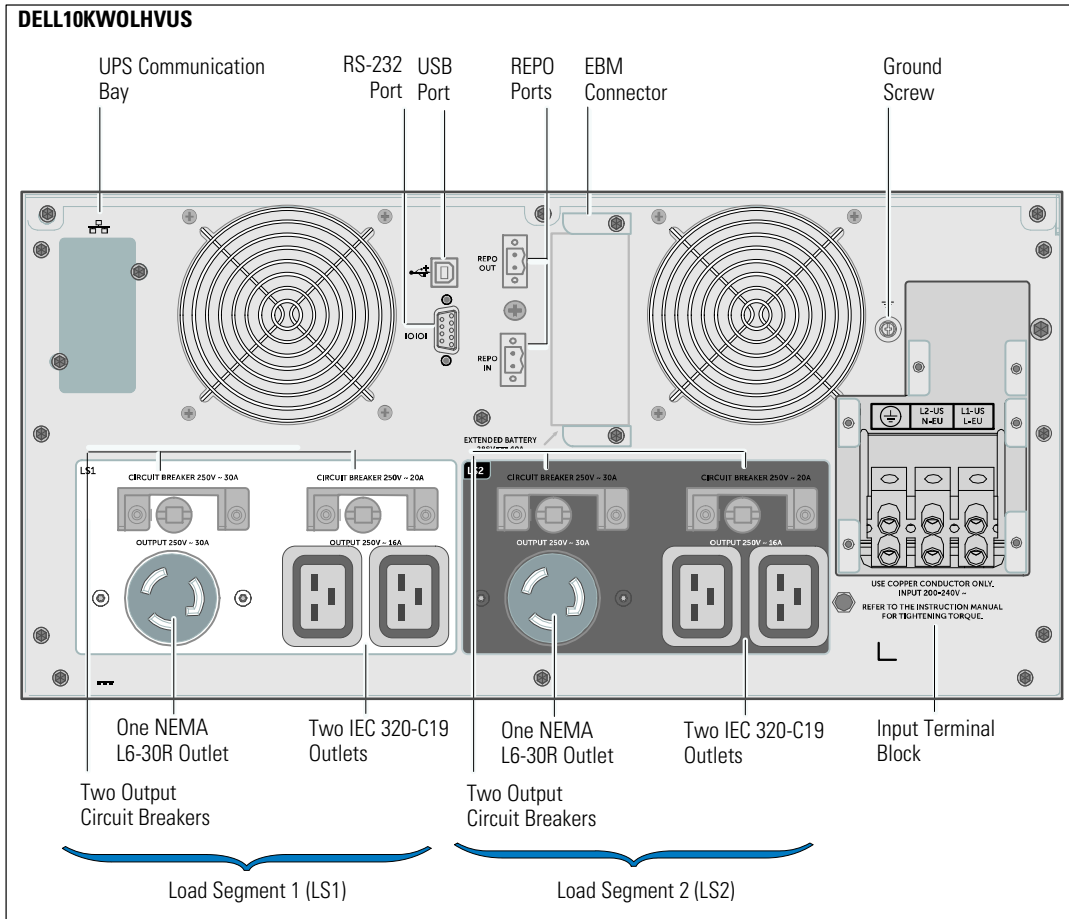

Figure 24. 10 kW, 208V (DELL10KWOLHVUS) Rear Panel

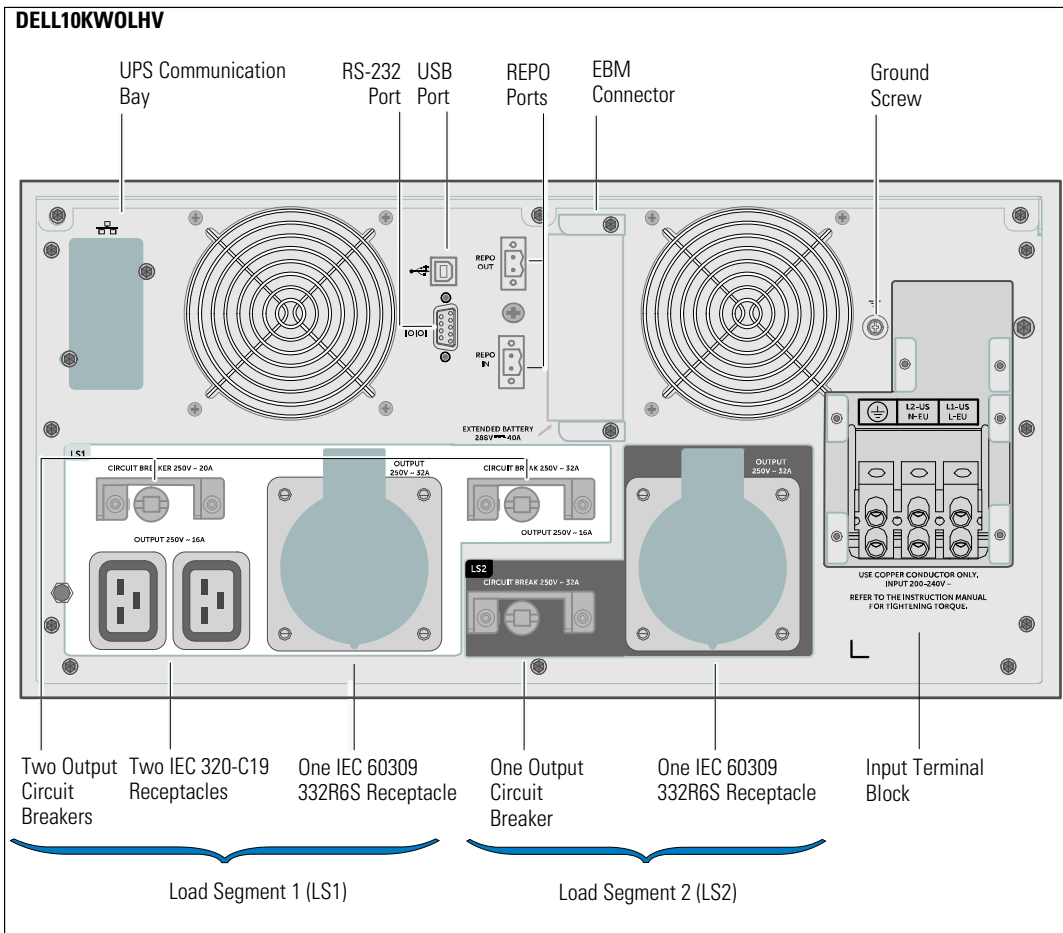

Figure 25. 10 kW, 230V (DELL10KWOLHV) Rear Panel

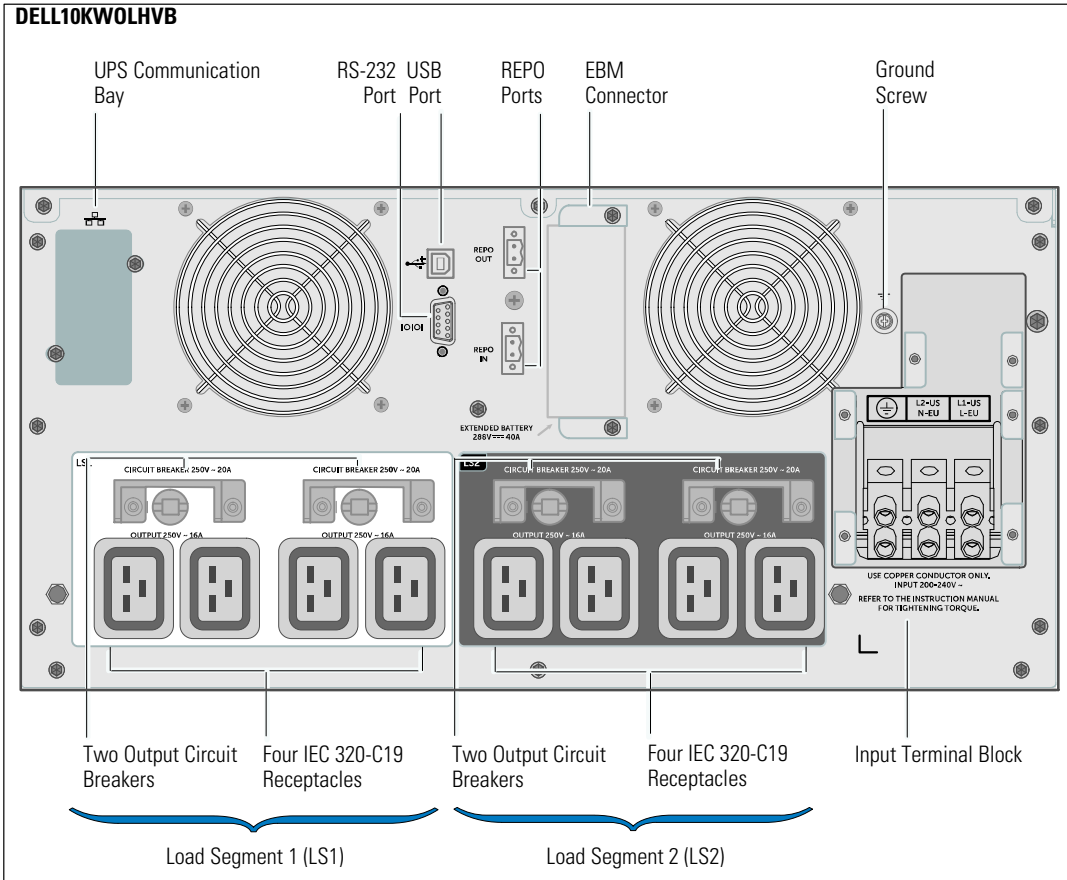

Figure 26. 10 kW, 230V (DELL10KWOLHVB) Rear Panel

Operation

This chapter contains information on how to use the UPS, including:

- UPS startup and shutdown
- Control panel and display functions
- Retrieving the event log
- Transferring the UPS between modes
- Power-setting strategy
- Behavior on overload
- Configuring load segments, battery settings, and automatic restart

Figure 27 shows Dell Online Rack UPS controls.

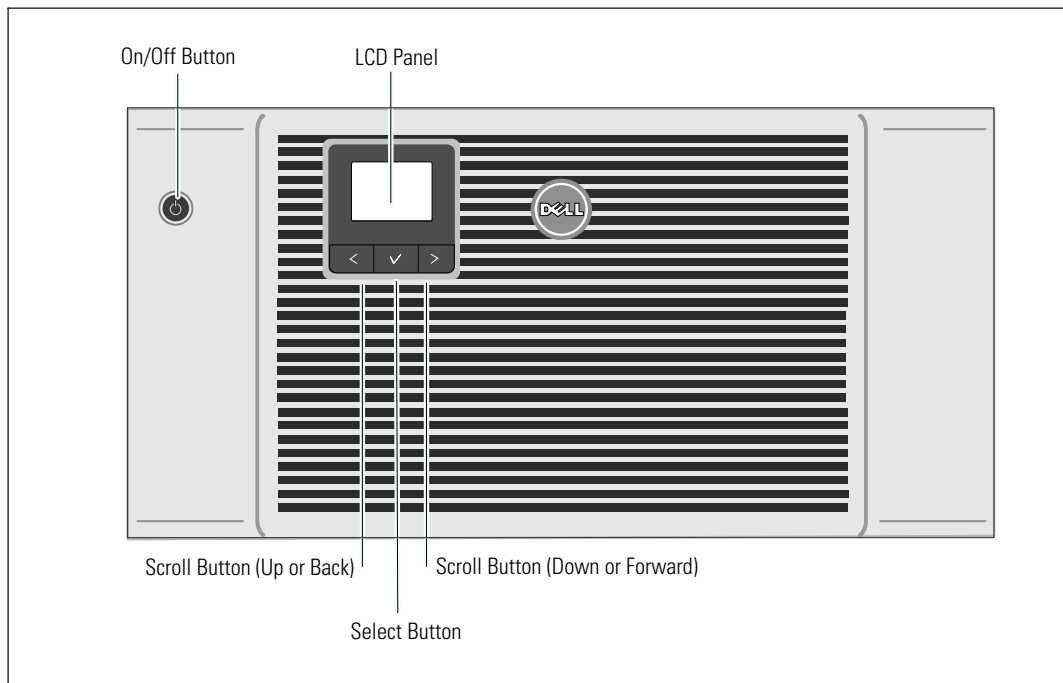

Figure 27. UPS Controls

UPS Startup and Shutdown

To start up or shut down the UPS, see:

- “Starting the UPS” on page 38
- “Starting the UPS on Battery” on page 38
- “UPS Shutdown” on page 39

Starting the UPS

To start the UPS:

- 1 Verify that the UPS is connected to utility power.
- 2 Switch on utility power where the UPS is connected.

The UPS front panel LCD display illuminates (see Figure 27). The Dell startup screen changes to the UPS status summary screen. The UPS front panel display shows the Standby mode icon .

- 3 Press the  button on the UPS front panel (see Figure 27).

After the startup is complete, the status icon changes to the appropriate icon based on the UPS operating mode. See Table 4 on page 42.

- 4 On the control panel, press the  button to check for active alarms or notices (see Figure 27). Resolve any active alarms before continuing. See “Troubleshooting” on page 84.

If there are no active alarms, a “No Active Alarms” message appears.

- 5 Verify that the Normal mode icon  appears on the UPS status summary screen, indicating that the UPS is operating normally and any loads are powered.

Starting the UPS on Battery



NOTE: Before using this feature, the UPS must have been powered by utility power with output enabled at least once.



NOTE: Utility power cannot be present at startup.





NOTE: Batteries should be charged.

To start the UPS on battery:

- 1 Press the  button on the UPS front panel until the UPS beeps.



The UPS front panel display illuminates, and the UPS begins the startup sequence.

The UPS cycles through Standby mode to Battery mode. The Battery mode icon  displays on the UPS status summary screen. The UPS supplies power to your equipment.

NOTE: The UPS does not assume the load if you press the  button less than three seconds.

2 Press the  button to check for active alarms or notices.

Ignore the “UPS on Battery” notice and notices that indicate missing utility power. Resolve other active alarms before continuing. See “Troubleshooting” on page 84. After correcting the alarms, restart if necessary.

You can prevent a battery start (requiring utility power at the next startup) by simultaneously pressing the  and  buttons for three seconds. To disable the battery start, see the Start on Battery setting on page 50.

UPS Shutdown

To shut down the UPS:

NOTE: If devices are connected, prepare them to be shut down.

1 Press the  button on the front panel for three seconds.

The UPS begins to beep. The UPS transfers to Standby mode.



NOTE: Releasing the  button before three seconds returns the UPS to its original operating state.

2 Switch off utility power where the UPS is connected.

After utility power is removed, the UPS fully shuts down in ten seconds.

Control Panel Functions

The UPS has a three-button graphical LCD. There are three buttons on the control panel:

-  Scroll up or back
-  Select
-  Scroll down or forward

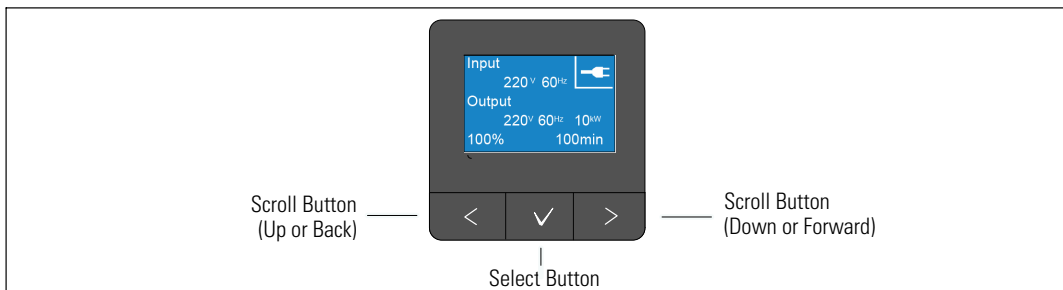

Figure 28. UPS LCD Panel Controls

Table 3 describes the functions and operation of the LCD control buttons.

Table 3. Control Button Functions

Control Button	Sequence	Function
<	Press for less than one second	Scroll back or up to the previous menu.
<	Press for longer than one second	Return/exit back one menu layer without initiating a command or changing a setting.
✓	Press for less than one second	Select the menu or option to be changed.
✓	Press for longer than one second	Save the setting being edited.
>	Press for less than one second	Scroll forward or down to the next menu option.
< >	Press both buttons for three seconds	Temporarily disable the battery startup feature until the next power cycle. The buzzer emits a one second beep to indicate that Battery Start has been disabled.
< ✓ >	Press all three buttons for five seconds	Shortcut for defaulting the language back to English. The buzzer emits a one second beep to indicate that the setting has changed to English.

To select an option:

- 1 When scrolling through the settings, the present setting displays for each selection.
- 2 Press and release the ✓ button to select the option.
The current setting for the option flashes when selected.
- 3 Use the < or > buttons to toggle the available options.
- 4 Set the new option by pressing the ✓ button again for longer than one second.

The option stops flashing.

 **NOTE:** The LCD has dual color backlight. Standard backlight is used to light up the display with white text and a blue background. When the UPS has a critical alarm, the backlight changes the text to dark amber and the background to red.

Changing the Language

Language selection is controlled through the user settings. See Table 7 page 48 for information on available languages.

Display Functions

The UPS provides useful information about the UPS itself, load status, events, measurements, identification, and settings through the front panel display.

Startup Screen

During startup, the Dell logo startup screen displays for five seconds and then defaults to the UPS status summary screen.

The display automatically returns to the UPS status summary screen when no button has been pressed for 15 minutes and no other screen has been locked by a user. When you return to the status summary screen, press the < button for longer than one second to exit back to the menu selections. Selecting UPS Status from the main menu list lets you to scroll through all of the UPS status menu screens, including the status summary screen.

A UPS status summary screen replaces the startup screen after the UPS is powered on. The UPS status summary screen displays until you press < to go to the first of the main menu selections.

Screen Locked

To lock a screen, press the ✓ button. The current view stays locked and does not automatically return to the default screen after time-out. When the screen is locked, the image of a key appears on the UPS status summary screen just to the left of the status icon.

Pushing any button returns the normal button function, unlocks the screen, and removes the lock symbol.

Only screens that have dynamic, real-time data updates can be locked. Applicable screens include the status summary screen, measurement screens, active alarms, and the battery status screen.

Operating Modes

The UPS status summary screens provide operating notification information, including operating mode.

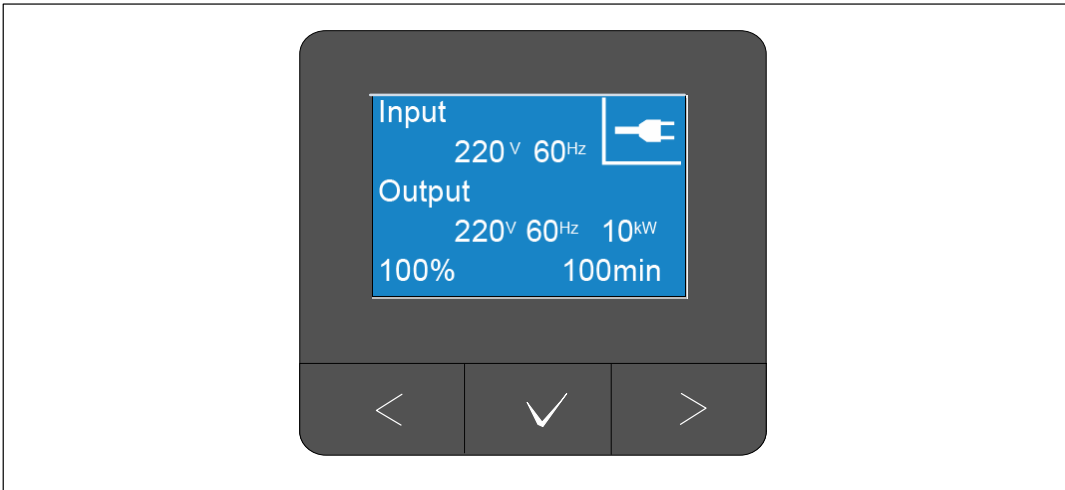

Figure 29. Example UPS Status Summary Screen (Normal Mode)

A unique status icon in the upper right corner of each status summary screen conveys the status of the UPS. Basic operating modes are described in Table 4.

Table 4. Operating Mode Status Icons



Icon	Mode	Description
	UPS Critical Failure	The UPS experienced a failure and is in Fault mode. Fault mode is a fail-safe state to protect the unit and the user from unsafe power output. There should be no power output. The status icon and background of the icon are flashing by inverting colors every second.
	UPS in Overload Condition	The UPS is overloaded and is in fault mode. Fault mode is a fail-safe state to protect the unit and the user from unsafe power output. There should be no power output. The status icon and background of the icon are flashing by inverting colors every second.

Table 4. Operating Mode Status Icons (continued)









Icon	Mode	Description
	Battery Mode	<p>The utility input is out of the specified operating range and the UPS is operating on battery power. The load is supplied from the battery through the inverter. When utility power returns, the UPS transfers to Normal mode operation while the battery recharges.</p> <p>The status icon and background of the icon are flashing. An audible alarm (0.5 seconds on/4.5 seconds off) accompanies the switch to Battery mode.</p>
	Bypass Mode	<p>The UPS is operating in Bypass mode through the static bypass switch. Battery mode is not available.</p> <p>The status icon and background of the icon are flashing by inverting colors every second.</p>
	Bad Battery Detected or Battery Disconnected	<p>The UPS detects a bad battery or that the battery is disconnected. The status icon and background of the icon are flashing, along with the outer shell of the battery symbol at the bottom.</p>
	UPS General Alarms Active	<p>Alarms are active. The status icon and background of the icon are flashing by inverting colors every second.</p>
	Battery Test Status	<p>The UPS is performing a battery test (started either automatically or manually). The battery provides power through the inverter even if the utility input is available and within operating range.</p>
	Normal Mode	<p>The UPS is operating in Normal mode from utility power. The UPS monitors and charges the batteries as needed and provides filtered power protection to your equipment.</p>
	High Efficiency Mode	<p>The UPS supplies the load power from the bypass source and stands ready to automatically transfer to standard double-conversion (Normal) operation as needed. The battery recharges when necessary.</p> <p>NOTE: The High Efficiency setting minimizes heat contribution to the rack environment.</p>

Table 4. Operating Mode Status Icons (continued)

Icon	Mode	Description
	Converter Mode	<p>The UPS inverter supplies the load from utility power while acting as a frequency converter, locking the UPS into a stable output frequency and transferring to Battery mode as necessary. However, the input and output frequency are not synchronized. Bypass mode is not available.</p> <p>NOTE: Use Converter mode to lock the UPS output frequency at 50 Hz or 60 Hz to suit power-sensitive equipment, or to provide 50 Hz output when the available standard utility input is 60 Hz (or the reverse).</p>
	Standby Mode	<p>When the UPS is turned off and remains connected to utility power, the UPS is in Standby mode and utility power supplies the connected equipment. The UPS is not supporting the load, but is ready to assume the load on command.</p>

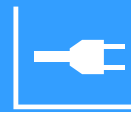
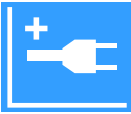
Active Notices and Alarms

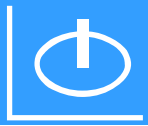
The notice and alarm screens are visible only when notices or alarms are active. There is a separate status summary screen for each active notice or alarm. If there are no active notices or alarms, a “No Active Alarms” message appears in a single screen between the UPS status summary and the battery status screen. If there are multiple notices or alarms, scroll through each notice or alarm screen to reach the first battery status screen.

 **NOTE:** Events are not shown in status summary screens. They appear only in the Event Log.

Battery Operating Status

Table 5 describes the available battery operating status notifications that are provided on status summary screens. Only one battery operating status is reported at a time.

Table 5. Battery Operating Status Notifications

Battery Status Notifications	Description
Battery charging	Batteries are charged in constant current mode.
Battery floating	Batteries are charged in constant voltage mode.
Battery resting	Batteries are connected but are not being charged or discharged. (This is part of the normal charging cycle.)
Battery discharging	Batteries are discharging.
Battery disconnected	Batteries are unavailable because they are disconnected.
Charger disabled	The charger is off. You can enable the Charger setting from the Settings menu (see page 52).

Event Log

The Event Log holds up to 50 events. You can scroll through the event screens, beginning with the most recent event.

 **NOTE:** The date format depends on the language selection.

The first row of each event screen contains the date (MM/DD/YYYY) and time (hh:mm:ss) at which the event occurred. The second row contains the type of event and code. The event description begins on the third row and may continue to the fourth row. The bottom right corner of the event screen displays two numbers: an ordering number of the event in the log, followed by the total number of events in the log.

If there are no events in the log, the event status summary screen displays “No events in log.”

See “Retrieving the Event Log” on page 56.

Measurements

The measurements screens provide useful measurement information on:

- Output watts, VA, current, power factor, voltage, and frequency
- Input voltage and frequency
- Battery voltage, percentage charged, and time remaining
- Instantaneous Headroom Watts remaining
- Peak Headroom Watts (the remaining watts available to support the load at peak demand, includes the date and timestamp of the peak demand)
- Peak Consumption Watts (the peak power demand on the UPS, includes the date and timestamp of the peak demand)
- Present kWh Consumption (the kWh demand on the UPS averaged over the past hour)
- Cumulative kWh Consumption (the total kWh usage, includes the date and timestamp since it was last reset)
- DC bus voltages (measured internal bus voltages for double conversion)



NOTE: For Peak Consumption Watts and Cumulative kWh Consumption, input level is not supported.

Control Screens

Table 6 describes the available control screens.

Table 6. Control Screens

Control Screens	Description
Go to Bypass	<p>Transfers the UPS system to internal Bypass mode.</p> <p>When the Go to Bypass command is issued, the screen immediately shows the message for five seconds: Manual Bypass Command. The option then changes to Go to Normal.</p> <p>When the Go to Normal command is issued, the screen immediately shows the message Normal Mode Command Sent for five seconds. The option then changes to Go to Bypass.</p>
Battery Test	<p>Schedule Battery Test: yes Cancel Battery test: no</p> <p>Starts a manual battery test.</p> <p>See “Testing Batteries” on page 78.</p>
Reset Error State	<p>Reset Alarms: yes no</p> <p>Manually clears any latched alarms, such as bad battery detected, overload, or DC Bus OV/UV.</p> <p>If a bad battery alarm was also active, reset the battery test status to “Not Tested.”</p>
Load Segments	<p>Load segment 1: on off</p> <p>Load segment 2: on off</p> <p>These on/off commands override automatic load segment on/off controls made by the Automatic Start Delay and Automatic On Battery Shutdown settings. See “Configuring Load Segments” on page 57.</p>
Restore Factory Settings	<p>Restore Factory Settings: yes no</p> <p>Available only in Standby mode.</p> <p>Restoring the factory settings:</p> <ul style="list-style-type: none">• Returns all user-configurable EEPROM settings to default factory settings• Resets all pending on/off commands• Clears the Event Log and resets all time stamps• Resets the battery test status• Initiates the Self Diagnostics test

Identification

The identification screens display the following UPS information:

- Type and model
- Part number
- Serial number
- Service tag information
- NMC firmware
- UPS firmware



NOTE: The NMC firmware screen displays only if the Network Management Card is installed. See “Dell UPS Network Management Card” on page 64.

Settings

Only available options are displayed.

User settings are not protected by default. You can enable the password through the User Password setting.

Table 7 displays the options that can be changed by the user.

Table 7. Settings

Description	Available Settings	Default Setting
Change Language	[English] [French] [German] [Spanish] [Japanese] [Simplified Chinese] [Russian] [Korean] [Traditional Chinese]	English
User Password	[Enabled] [Disabled] If Enabled, the default password is USER. NOTE: If you enter an incorrect password, the message “Wrong Password” appears. Press any button to return to the password screen and retry the password.	Disabled
Audible Alarms	[Enabled] [Disabled] NOTE: If you disable audible alarms, it takes effect instantly and remains disabled, even after a power cycle. This feature differs from the mute feature where the horn is temporarily silenced on any button press, but turns on again if a new alarm is triggered.	Enabled

Table 7. Settings (continued)

Description	Available Settings	Default Setting
Set Date and Time	Set Month, Day, Year, Hours, Minutes, and Seconds Date: mm/dd/yyyy Time: hh:mm:ss NOTE: The date format is dependent on the language selection. NOTE: Time is a 24-hour clock.	01/01/2012 12:00:00
Control Commands from Serial Port	[Enabled] [Disabled] If Enabled, control commands are accepted through the serial port, USB ports, or option card. If Disabled, configuration and load control commands are restricted to LCD only.	Enabled
Output Voltage	[208V] [230V] [Auto-sensing] NOTE: Numerical output voltage settings that are configured in Standby mode take effect immediately. Auto sensing and any settings that are configured outside of Standby mode take effect after the next power off and restart. Selecting auto sensing disables the battery start feature until after the next successful startup on utility power.	Auto-sensing NOTE: The default auto sensing runs once to set the output voltage and then is disabled.
Output Frequency	[50Hz] [60Hz] [Auto-sensing] NOTE: Numerical output voltage settings that are configured in Standby mode take effect immediately. Auto sensing and any settings that are configured outside of Standby mode take effect after the next power off and restart. Selecting auto sensing disables the battery start feature until after the next successful startup on utility power.	Auto-sensing NOTE: The default auto sensing runs once to set the output voltage and then is disabled.
Overload Alarm Level	[10%] [20%] [30%]...[100%] If 100%, the UPS issues an Output Overload alarm at load > 100%. NOTE: Output Overload Level 1 by default is set to 100% and is configurable from 10% to 100% in 10% increments through the LCD setting menu. This feature allows customers to be alerted before the UPS has reached its rated capacity limits.	100%
Power strategy	[Normal] [High Efficiency] [Converter] See “Setting the Power Strategy” on page 54.	Normal

Table 7. Settings (continued)

Description	Available Settings	Default Setting
Automatic Start Delay	[Off] [0s] [1s] [2s]...[32767s] See “Configuring Load Segments” on page 57.	0s: Load Segment 1 (LS1) 1s: Load Segment 2 (LS2)
Automatic on Battery Shutdown	[Off] [0s] [1s] [2s]...[32767s] See “Configuring Load Segments” on page 57.	Off
Start on Battery	[Enabled] [Disabled] NOTE: Battery start is disabled from the factory and remains disabled until the UPS has been powered from utility and enters Standby mode. After the UPS has been started once from utility, the Start on Battery feature is automatically enabled. If this is set by the user, it remains set.	Enabled
Battery Saving Mode	[Disabled] [10%] [20%] [30%]...[100%] The UPS output is turned off in five minutes if the UPS is on battery and output power is below the selected level.	Disabled
On Battery Notice Delay	[0s] [1s] [2s]...[99s] The UPS issues a “UPS on battery” notice in the specified number of seconds after the UPS starts to discharge the batteries.	0s
Site Wiring Fault Alarm	[Enabled] [Disabled]	Disabled
Bypass Voltage Low Limit	[-6%] [-7%]...[-20%] of nominal The Bypass operation is disabled if the measured bypass voltage level is below the nominal output voltage (-15%). NOTE: The Qualify Bypass setting may overrule the Bypass Voltage Low Limit setting.	-15% of nominal
Bypass Voltage High Limit	[+6%] [+7%]...[+20%] of nominal The Bypass operation is disabled if the measured bypass voltage level is above the nominal output voltage (+10%). NOTE: The Qualify Bypass setting may overrule the Bypass Voltage High Limit setting.	+10% of nominal

Table 7. Settings (continued)

Description	Available Settings	Default Setting
Qualify Bypass	<p>[Always] [Never] [Bypass Disabled]</p> <p>If Always, Bypass operation is allowed when:</p> <ul style="list-style-type: none"> • Bypass voltages > the value set for Bypass Voltage Low Limit • Bypass voltages < the value set for Bypass Voltage High Limit • Bypass frequency > (nominal frequency -3 Hz) • Bypass frequency < (nominal frequency +3 Hz) • Inverter is synchronized with Bypass when unsynchronized transfers are disabled by the value set for Unsynchronized Transfers <p>If Never, Bypass operation is always allowed; voltage and frequency limits are not in use.</p> <p>If Bypass Disabled, Bypass operation is prohibited.</p>	Always
Synchronization Window	<p>[Sync Disabled] [± 0.5 Hz] [± 1.0 Hz] [± 1.5 Hz] [± 2.0 Hz] [± 2.5 Hz] [± 3.0 Hz]</p> <p>If ± 3.0 Hz, on inverter operation the inverter tries to synchronize with the Bypass when the Bypass frequency is not more than 3 Hz from the nominal output frequency; otherwise, the inverter goes to nominal frequency. On Bypass mode, the sync window is always ± 3 Hz.</p> <p>NOTE: In Sync Disabled state, if the Bypass operation is allowed, the UPS synchronizes only when it is operating on Bypass mode.</p>	± 3.0 Hz
Unsynchronized Transfers	<p>[Enabled] [Disabled]</p> <p>If Enabled, unsynchronized transfers to the Bypass are allowed.</p> <p>If Disabled, unsynchronized transfers to the Bypass are not allowed.</p> <p>NOTE: The Qualify Bypass setting may overrule the Unsynchronized Transfers setting.</p>	Enabled
External Battery Modules (EBMs)	<p>[0] [1]</p> <p>See “Configuring the UPS for an EBM” on page 60.</p>	0

Table 7. Settings (continued)

Description	Available Settings	Default Setting
Charger	[Enabled] [Disabled] If Enabled, batteries charge normally. If Disabled, the battery charger is off.	Enabled
Battery Charge % to Restart	[0%] [10%] [20%] [30%]...[100%] When enabled, automatic restart is made when the battery charge state reaches the selected level. If set to 0%, the feature is disabled.	0%
Battery Low Alarm	[Immediate] [2 min] [3 min] [5 min] If you select a value, the battery low alarm triggers when the set amount of backup time (approximately) remains in the batteries.	3 min
Automatic Battery Support Tests	[Enabled] [Disabled] See “Running Automatic Battery Tests” on page 61.	Enabled
Reset Peak Consumption Watts	[No] [Yes] If No, no action. If Yes, the Peak Consumption Watts value is cleared and the date and time stamp for this statistic is set to the current date and time.	No
Reset Cumulative Consumption kWh	[No] [Yes] If No, no action. If Yes, the Cumulative Consumption kWh value is cleared and the date and time stamp for this statistic is set to the current date and time.	No
Reset Peak Headroom Watts	[No] [Yes] If No, no action. If Yes, the Peak Headroom Watts value is cleared and the date and time stamp for this statistic is set to the current date and time.	No

Table 7. Settings (continued)

Description	Available Settings	Default Setting
Clear Event Log	The number after “Total events” shows how many events are currently stored in the log. Press the ✓ button for longer than one second to reset the event count to zero and clear the log.	—
LCD Contrast	[-5], [-4], [-3], [-2], [-1], [+0], [+1], [+2], [+3], [+4], [+5] The LCD Contrast is adjustable from -5 to +5. This range covers the maximum adjustment for contrasting the background with the text in the visual display of the control panel.	+0

Transferring the UPS Between Modes

Transferring between modes includes:

- Transferring from Normal to Bypass mode
- Transferring from Bypass to Normal mode

Transferring from Normal to Bypass Mode

To transfer from Normal to Bypass mode:

- 1 Press the < button for longer than one second to go to the main menu selection and scroll down to the Control menu using the > button.
- 2 Press the ✓ button to enter the Control menu.
- 3 Select Go to Bypass.

The text on the screen changes to Manual Bypass Command Sent. The Bypass mode icon  flashes, indicating Bypass mode.

Transferring from Bypass to Normal Mode

To transfer from Bypass to Normal mode:

- 1 Press the **<** button for longer than one second to go to the main menu selection and scroll down to the Control menu using the **>** button.
- 2 Press the **✓** button to enter the Control menu.
- 3 Select Go to Normal.

The text on the screen changes to Normal Command Sent. The Normal mode icon  flashes, indicating Normal mode.

Setting the Power Strategy

The UPS has the following power strategy settings:

- **Normal.** The UPS operates in Normal mode (powering the load from utility power).
- **High Efficiency.** The UPS operates in High Efficiency mode (powering the load from the bypass source but ready to transfer to Normal mode as needed). The UPS is highly sensitive to line fluctuations and transfers out of High Efficiency mode at $\pm 5\%$ of nominal voltage or $\pm 1\%$ of nominal frequency. If the UPS transfers to Normal mode, the UPS automatically transfers back to High Efficiency mode after five minutes of stable power. Transfers to High Efficiency mode are limited to three times in one hour.
- **Converter.** The UPS operates as a frequency converter, powering the load from acceptable utility power while providing a stable output frequency. Bypass operation and bypass-related alarms are disabled.

Table 8 describes the UPS behavior in Converter mode in detail. To set the output frequency, see “Settings” on page 48.

To set the power strategy, complete the following steps:

- 1 Make sure that the UPS is in Standby mode.
- 2 From the main menu, press the **>** button to scroll to the Settings menu, and press the **OK** button.
- 3 Press the **>** button to scroll to Power Strategy, and press the **OK** button.
- 4 Press the **>** button to select the power strategy that you want to set and press the **OK** button.
- 5 Press the **OK** button for one second to confirm.



NOTE: The UPS tests the bypass source for five consecutive minutes of stable power before it transfers to High Efficiency mode.

Table 8. UPS Behavior in Converter Mode

Load	Output Frequency Setting	Input Frequency (Hz)	Output Frequency (Hz)	UPS Behavior	
$\leq 50\%$	50 Hz	47–53	47–53	UPS in Converter mode synchronizes the output frequency with the input frequency.	
		45–46 or 54–65	50	UPS in Converter mode converts the input frequency to 50 Hz output frequency.	
		<45 or >65	50	UPS transfers to Battery mode to provide 50 Hz output frequency.	
	60 Hz	57–63	57–63	UPS in Converter mode synchronizes the output frequency with the input frequency.	
		45–56 or 64–65	50	UPS in Converter mode converts the input frequency to 60 Hz output frequency.	
		<45 or >65	50	UPS transfers to Battery mode to provide 60 Hz output frequency.	
	> 50%	50 Hz	47–53	47–53	UPS in Converter mode synchronizes the output frequency with the input frequency.
			45–46 or 54–55	50	UPS in Converter mode converts the input frequency to 50 Hz output frequency.
			<45 or >55	50	UPS transfers to Battery mode to provide 50 Hz output frequency.
60 Hz		57–63	57–63	UPS in Converter mode synchronizes the output frequency with the input frequency.	
		55–56 or 64–65	50	UPS in Converter mode converts the input frequency to 60 Hz output frequency.	
		<55 or >65	50	UPS transfers to Battery mode to provide 60 Hz output frequency.	

Retrieving the Event Log

To retrieve the Event Log:

- 1 Press the < button for longer than one second to go to the main menu selection and scroll down to the Event Log menu using the > button.
- 2 Press the ✓ button to enter the Event Log list.
- 3 Scroll through the listed events, notices, and alarms using either the < button or the > button.

Behavior on Overload

See Table 9 for an explanation of how the UPS responds to an overload condition.

Table 9. Behavior on Overload

Overload Severity	Load Level	On Utility Power	On Bypass/High Efficiency	On Battery/Converter
Level 1	100% to 101%	Overload alarm and supports load indefinitely	Overload alarm and supports load indefinitely	Overload alarm and supports load until low battery shutdown level is reached
Level 2	102% to 110%	Transfers to Bypass mode in 12 sec (± 1 sec). If Bypass mode is not available, transfers to Fault mode after 12 sec (± 1 sec).	Transfers to Fault mode in 2 min (± 1 sec)	Transfers to Fault mode in 12 sec (± 1 sec) or when low battery shutdown level is reached
Level 3	> 110%	Transfers to Bypass mode immediately. If Bypass mode is not available, transfers to Fault mode after 300 ms to 1 sec.	Transfers to Fault mode in 300 ms to 1 sec	Transfers to Fault mode in 300 ms to 1 sec

Configuring Load Segments

Load segments are sets of receptacles that can be controlled by the Dell MUMC and Dell ULNM software, the Dell UPS Network Management Card, or through the LCD display, providing an orderly shutdown and startup of your equipment. For example, during a power outage, you can keep key pieces of equipment running while you turn off other equipment. This feature allows you to save battery power.

Each Dell Online Rack model has two configurable load segments (shown in Figure 30).

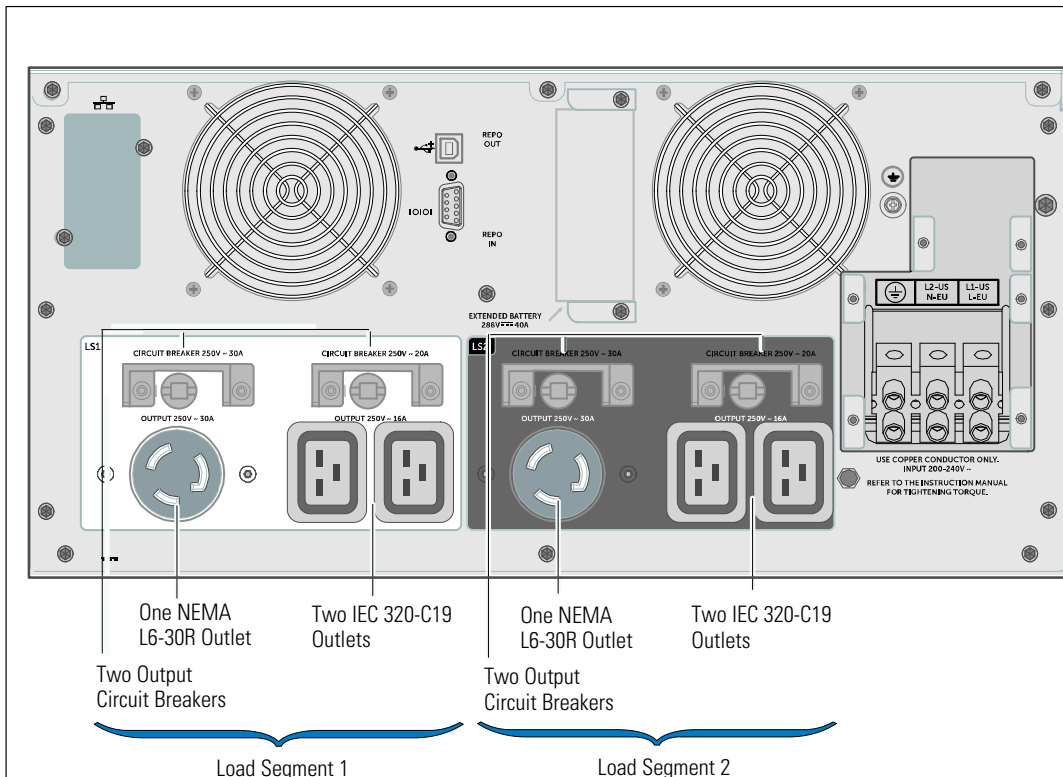

Figure 30. Load Segments (DELL10KWOLHVUS model shown)

To control the load segments with power management software, see your power management software manual for details (refer to the Software CD or www.dellups.com for the latest information).

Controlling Load Segments Through the Display

To control the load segments through the display:

- 1 Press the < button for longer than one second to go to the main menu selection and scroll down to the Control menu using the > button.
- 2 Press the ✓ button to enter the Control menu.
- 3 Use the > button to scroll to Load Segments.
- 4 Press the ✓ button.
The current setting for the option flashes when selected.
- 5 Select the desired load segment using the < and > buttons.
- 6 Set the desired load segment ON or OFF using the ✓ button.
- 7 Press the ✓ button for longer than one second to confirm.
- 8 Set the other load segment if applicable.

Configuring Automatic Start Delay

You can configure a load segment to turn on automatically after the utility power returns, if it was shut down by:

- The ⏻ button
- An external command with auto-restart option
- Battery under voltage state
- Automatic on battery shutdown command

You can specify the restart delay time for each load segment: select zero seconds (0s is the default) to restart immediately, select 1–32767 seconds to delay for the specified time, or select Off.

To set the restart delay times for each load segment:

- 1 Press the < button for longer than one second to go to the main menu selection and scroll down to the Settings menu using the > button.
- 2 Press the ✓ button to enter the Settings menu.
- 3 Use the > button to scroll to the Automatic Start Delay option and press the ✓ button.
The current setting for the option flashes when selected.
- 4 Set the restart delay for one load segment using the < and > buttons.

- 5 Press the ✓ button to confirm.
- 6 Set the restart delay for the other load segment if applicable.
- 7 Press the ✓ button to confirm.



NOTE: Load segment On/Off commands issued through the Control menu override the user settings for load segments.



NOTE: There is an additional built-in one-second delay between closing load segment 1 and 2 when an On command is issued for both segments at the same time.

Configuring Automatic on Battery Shutdown

If set to Off (default), the load segment turns off only when commanded manually by the ⏻ button, an external command, or through the display (Control > Load Segments).

If set to zero seconds (0s), the load segment turns off automatically when the UPS on Battery state activates.

If you select a value, the load segment turns off automatically after the selected delay while the UPS operates on battery, but the shutdown is cancelled if the utility returns before the delay has expired.

To set the shutdown times for each load segment:

- 1 Press the < button for longer than one second to go to the main menu selection and scroll down to the Settings menu using the > button.
- 2 Press the ✓ button to enter the Settings menu.
- 3 Use the > button to scroll to the Automatic on Battery Shutdown option and press the ✓ button.
The options display and the current settings flash when selected.
- 4 Set the shutdown delay for one load segment using the < and > buttons.
- 5 Press the ✓ button to confirm.
- 6 Set the shutdown delay for the other load segment if applicable.
- 7 Press the ✓ button to confirm.

Configuring Battery Settings

Configure the UPS settings for an installed EBM, including whether to run automatic battery tests and automatic restart configuration.

Configuring the UPS for an EBM

If the UPS is not configured for the EBM, the UPS reports less battery time remaining on the UPS front panel and to any remote software. You may receive a shutdown warning prematurely. To ensure maximum battery runtime when using power management software, configure the UPS for the EBM:

- 1 Press the **<** button for longer than one second to go to the main menu selection and scroll down to the Settings menu using the **>** button.
- 2 Press the **✓** button to enter the Settings menu.
- 3 Use the **>** button to scroll to the External Battery Modules option and press the **✓** button.
The battery number value begins to flash.
- 4 Set the battery number value using the **<** and **>** buttons.

Configuration	Setting
UPS only (internal batteries)	0 (default)
UPS + 1 EBM	1

NOTE: Runtime is automatically adjusted based on present load levels and whether an EBM is configured.

 **NOTE:** This value represents to the number of attached EBM units, not the number of battery strings.

- 5 Press the **✓** button to confirm.

Running Automatic Battery Tests

The automatic discharge test, enabled by default, runs during the transition from Float to Rest mode. After the test completes, the charge cycle restarts to completely charge the batteries and then continues to Rest mode normally. The automatic test runs approximately once every three months and does not run again until after three more Float to Rest mode transitions. If a manual battery test is requested, the automatic battery test timer is reset so it will not run for the next three months.

For an automatic battery test to run:

- The Automatic Battery Tests setting must be enabled for the automatic battery tests to run. (See the following section, “Configuring Automatic Battery Tests.”)
- The batteries must be fully charged.
- The UPS must be in Normal mode or High Efficiency with no active alarms.
- The load must be higher than 10%.

Configuring Automatic Battery Tests

To configure the automatic battery tests:

- 1 Press the < button for longer than one second to go to the main menu selection and scroll down to the Settings menu using the > button.
- 2 Press the ✓ button to enter the Settings menu.
- 3 Use the > button to scroll to the Automatic Battery Tests option and press the ✓ button.
The option begins to flash.
- 4 Select whether to enable or disable the automatic battery test using the < and > buttons.
- 5 Press the ✓ button to confirm.

Configuring Automatic Restart

The UPS automatically restarts if the utility power returns after the output was shut off due to depleted batteries, a shutdown input signal, or an automatic shutdown command.

You can set the load segments for the amount of time to delay the restart when utility power returns, using the Automatic Start Delay setting. See “Configuring Load Segments” on page 57. You can also configure UPS restart to depend on the battery charge level, using the Battery Charge % to Restart setting from the Settings menu (see page 52).

Additional UPS Features

This chapter describes:

- Communication ports (RS-232 and USB)
- Dell Network Management Card
- Dell Multi-UPS Management Console (MUMC) and Dell UPS Local Node Manager (ULNM) Software
- Dell Environmental Monitoring Probe (EMP)

RS-232 and USB Communication Ports

To establish communication between the UPS and a computer, connect your computer to one of the UPS communication ports using an appropriate communication cable (RS-232 cable not supplied). See “UPS Rear Panels” on page 34 for the communication port locations.

When the communication cable is installed, power management software can exchange data with the UPS. The software polls the UPS for detailed information on the status of the power environment. If a power emergency occurs, the software initiates the saving of all data and an orderly shutdown of the equipment.

The cable pins for the RS-232 communication port are identified in Figure 31, and the pin functions are described in Table 10.

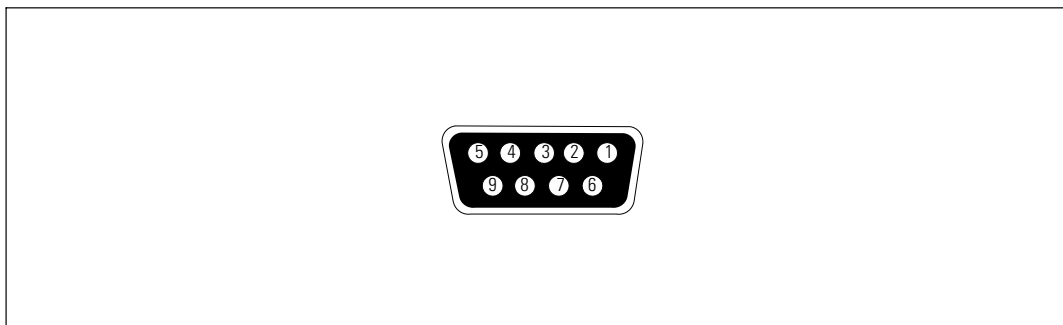

Figure 31. RS-232 Communication Port (DB-9 Connector)

Table 10. RS-232 Communication Port Pin Assignment

Pin	Signal Name	Function	Direction from the UPS
1		Unused	—
2	Tx	Transmit to external device	Out
3	Rx	Receive from external device	In
4		Unused	—
5	GND	Signal common (tied to chassis)	—
6		Unused	—
7		Unused	—
8		Unused	—
9		Unused	—

NOTE: Unused pins must be left free on all models.

Dell UPS Network Management Card (Optional)

The Dell Online Rack 10 kW UPS has one available communication bay, which supports the optional Dell UPS Network Management Card. See Figure 32 for the location of the communication bay.

 **NOTE:** It is not necessary to shut down the UPS before installing a communication card.

- 1 Remove the slot cover secured by two screws. Retain the screws.
- 2 Insert the communication card into the slot.
- 3 Secure the card with the retained screws.

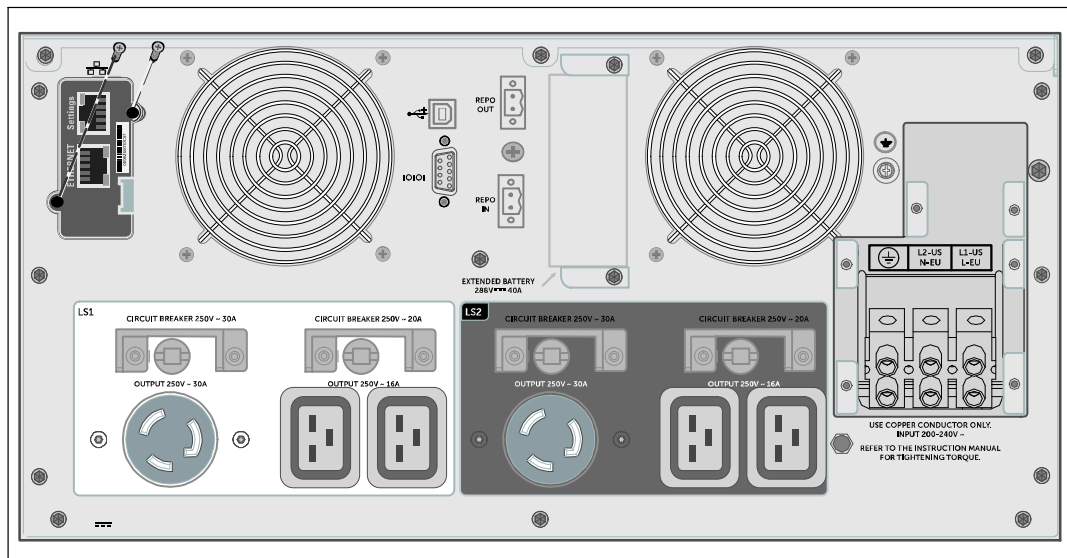

Figure 32. Installing the Dell UPS Network Management Card (DELL10KWOLHVUS model shown)

For details on disabling control commands from the Dell UPS Network Management Card, see the Control Commands from Serial Port setting on page 49.

Refer to the *Dell Network Management Card User's Guide* for more information.

Environmental Monitoring Probe (Optional)

The EMP is an optional connectivity device that lets you remotely monitor the temperature, humidity, and status of two contact devices through a standard Web browser, providing greater power management control and flexible monitoring. Use the EMP with any Dell UPS equipped with a Dell Network Management Card.

Dell MUMC and Dell ULNM Software

Each Dell Online Rack 10 kW UPS ships with Dell MUMC and Dell ULNM application software.

The Dell MUMC and Dell ULNM software provides up-to-date graphics of UPS power and system data and power flow. This software also gives you a complete record of critical power events, and it notifies you of important UPS or power information. If there is a power outage and the Dell Online Rack UPS battery power becomes low, the software can automatically shut down your computer system to protect your data before the UPS shutdown occurs.

For details on disabling control commands from the software, see the user setting for Control Commands from Serial Port setting on page 49.

UPS Maintenance

This chapter explains how to:

- Care for the UPS and batteries
- Transport the UPS
- Store the UPS and batteries
- Test the batteries
- Update the UPS firmware



CAUTION: Before performing the procedures in this section, read and follow the safety instructions in the “Safety and Warning” Chapter on page 9. Also follow the safety instructions and important regulatory information in your *Safety, Environmental, and Regulatory Information* document.

UPS and Battery Care

For the best preventive maintenance, keep the area around the UPS clean and dust-free. If the atmosphere is very dusty, clean the outside of the system with a vacuum cleaner. For full battery life, keep the UPS at an ambient temperature of 25°C (77°F).



NOTE: The batteries in the UPS are rated for a 3–5 year service life. The length of service life varies, depending on the frequency of usage and ambient temperature. Batteries used beyond expected service life will often have severely reduced runtimes. Replace batteries at least every 5 years to keep units running at peak efficiency.

Transporting the UPS



NOTE: The internal UPS batteries **MUST** be disconnected before transport.



CAUTION: The following procedure should be performed or supervised by personnel knowledgeable about batteries and the required precautions. Keep unauthorized personnel away from batteries.

If the UPS requires any type of transportation, the batteries must be disconnected (but not removed) before the unit is transported.

To prepare the UPS for transport:

- 1 Verify that the UPS is off and disconnected from utility power.
- 2 Remove the UPS front cover (see Figure 33):

Hold the right side of the cover against the chassis. Unsnap the left side of the cover and pull it forward.

Pull the right-side front cover tab from the chassis and remove the front cover.

Set the front cover aside.

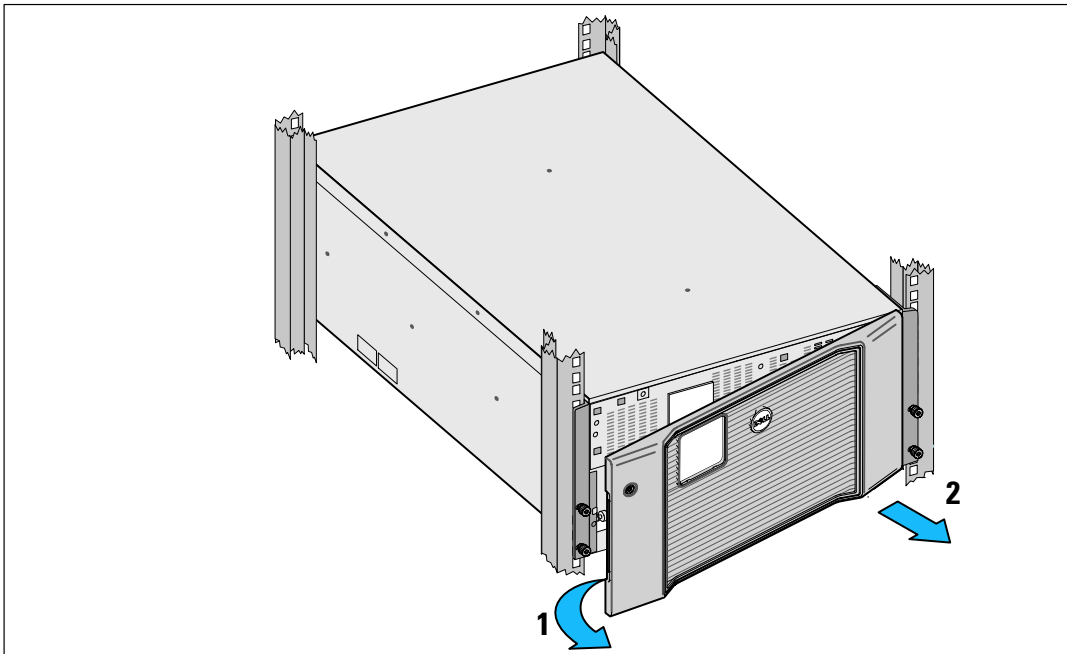

Figure 33. Removing the UPS Front Cover

3 Remove both battery retaining brackets from the UPS (Figure 34):

Locate the left (labeled **L**) retaining bracket. On the left side of the chassis, turn the thumbscrew counter-clockwise to release the left retaining bracket.

Push the bracket toward the center post to disengage it from the chassis. Swing the bracket toward you and pull the bracket to the left to remove it. Set the bracket aside.

Locate the right (labeled **R**) retaining bracket. On the right side of the chassis, turn the thumbscrew counter-clockwise to release the right retaining bracket.

Push the bracket toward the center post to disengage it from the chassis. Swing the bracket toward you and pull the bracket to the right to remove it. Set the bracket aside.

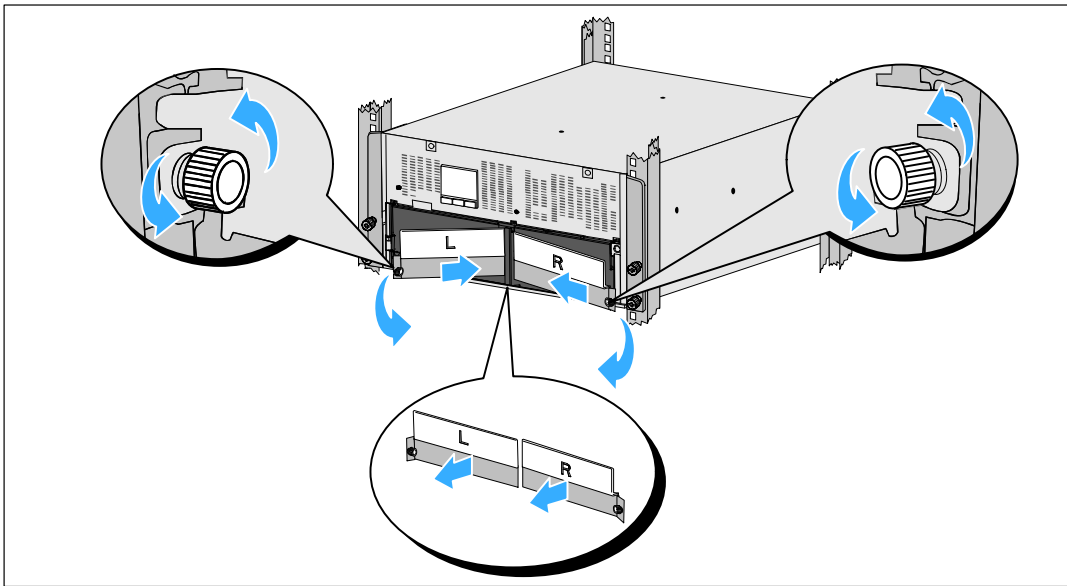

Figure 34. Removing the Battery Retaining Brackets

4 Disconnect the battery connectors (see Figure 35):

Locate the battery jumpers tucked into the small shelf at the top of the center post. Pull them off the shelf and disconnect them.

Locate and disconnect the remaining battery connectors for the left and right battery trays.

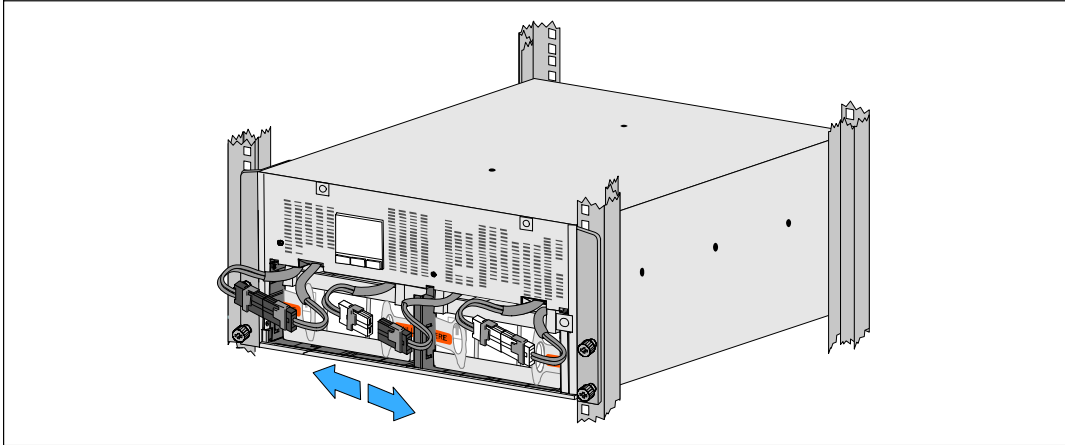

Figure 35. Disconnecting the Battery Connectors



NOTE: The battery retaining brackets are labeled L (Left) and R (Right) to indicate where they must be installed.

- 5 Replace the left (L) and right (R) battery retaining brackets (see Figure 36):

For the first battery retaining bracket, insert the bracket tab into the channel on the side of the center post. Fit the connected battery cables snugly behind the retaining bracket.

Align the end of the battery retaining bracket with the channel on the side of the chassis.

Push the bracket until it is firmly seated into the side channel.

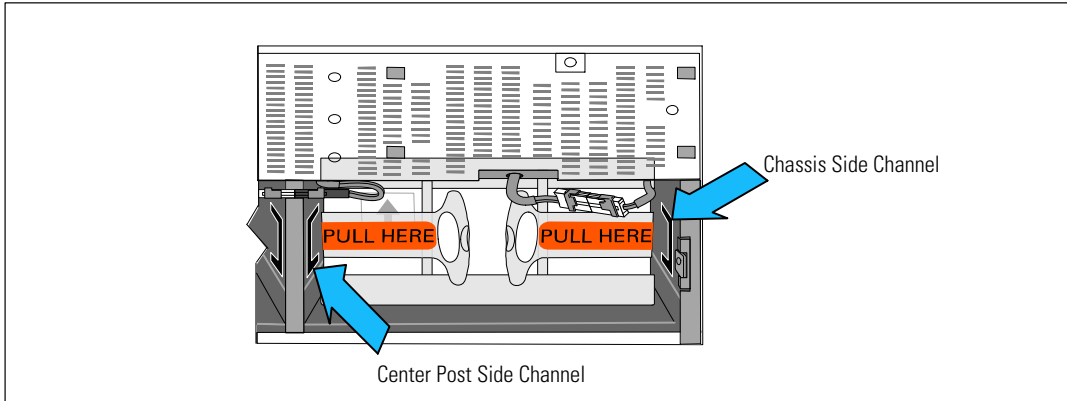

Figure 36. Inserting the bracket into the Channels

Turn the thumbscrew clockwise to secure the bracket.

Repeat to replace the second battery retaining bracket.

6 Replace the UPS front cover (see Figure 37).

Align the front cover with the front of the chassis.

Insert the right-side tabs on the front cover into the right-side chassis tab openings.

Push the left side of the cover forward and snap it to the chassis.



NOTE: Ensure that the LCD panel on the UPS chassis aligns with the LCD window on the front cover before securing the cover to the chassis.

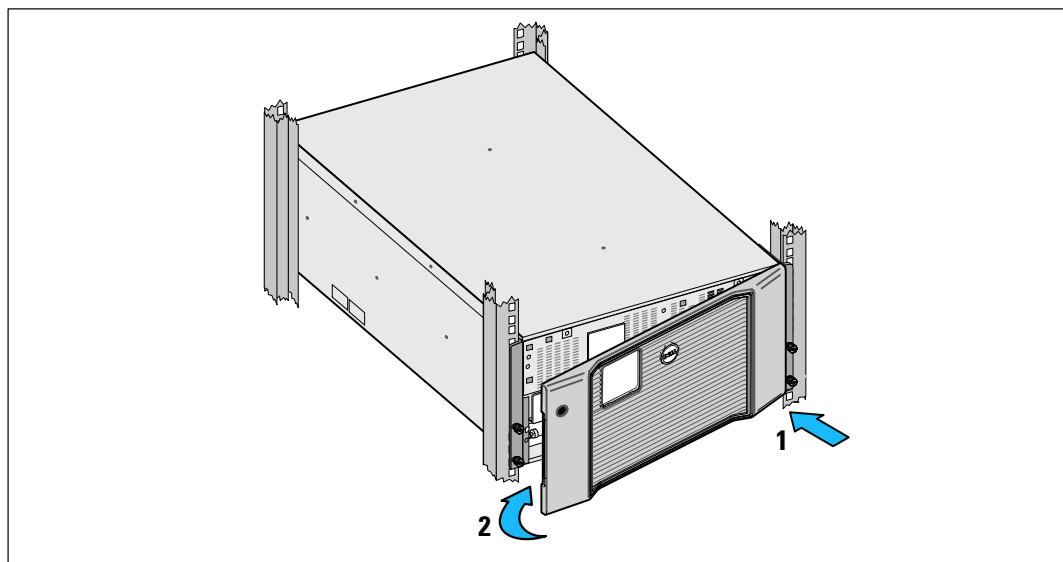

Figure 37. Replacing the UPS Front Cover

Recharging and Replacing Batteries

If you store the UPS for a long period, recharge the battery every 6 months by connecting the UPS to utility power. The batteries charge to 90% capacity in approximately 4 hours. However, it is recommended that the batteries charge for 48 hours after long-term storage.

You should track recharge dates. Log the last date the batteries were recharged. Do not use the UPS if the last recharge date was more than six months ago.

When the status summary screen displays the UPS fault icon with the “Service Battery” alarm and the audible alarm sounds continuously, the batteries may need replacing.

Contact your service representative to order new batteries.



NOTE: With the user-replaceable battery feature, UPS batteries can be replaced easily without turning the UPS off or disconnecting the load.

To replace the UPS batteries:

1 Remove the UPS front cover (see Figure 38):

Hold the right side of the cover against the chassis. Unsnap the left side of the cover and pull it forward.

Pull the right-side front cover tab from the chassis and remove the front cover.

Set the front cover aside.

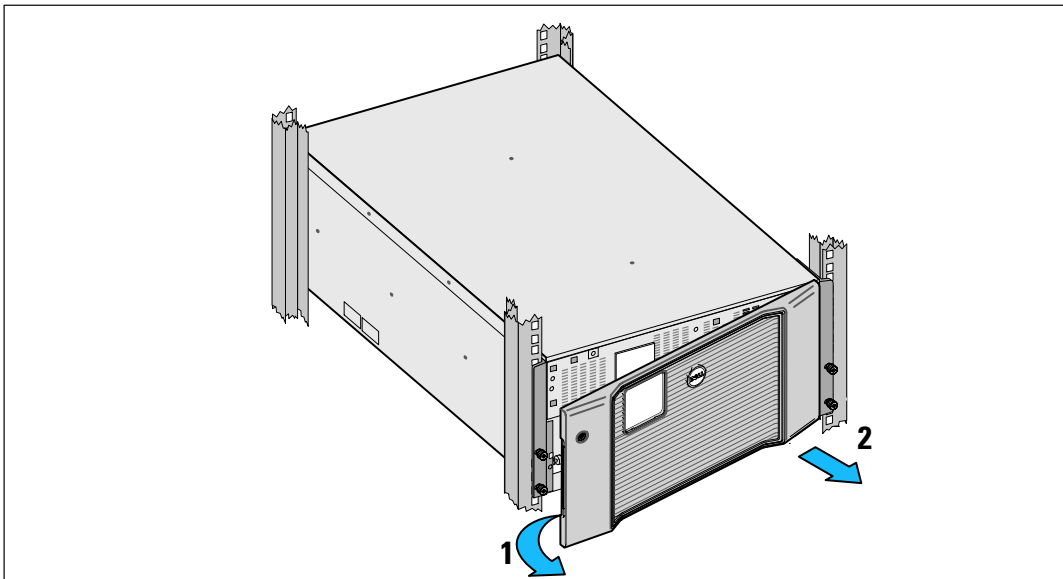

Figure 38. Removing the UPS Front Cover

2 Remove both battery retaining brackets from the UPS (see Figure 39):

Locate the left (labeled **L**) retaining bracket. On the left side of the chassis, turn the thumbscrew counter-clockwise to release the left retaining bracket.

Push the bracket toward the center post to disengage it from the chassis. Swing the bracket toward you and pull the bracket to the left to remove it. Set the bracket aside.

Locate the right (labeled **R**) retaining bracket. On the right side of the chassis, turn the thumbscrew counter-clockwise to release the right retaining bracket.

Push the bracket toward the center post to disengage it from the chassis. Swing the bracket toward you and pull the bracket to the right to remove it. Set the bracket aside.

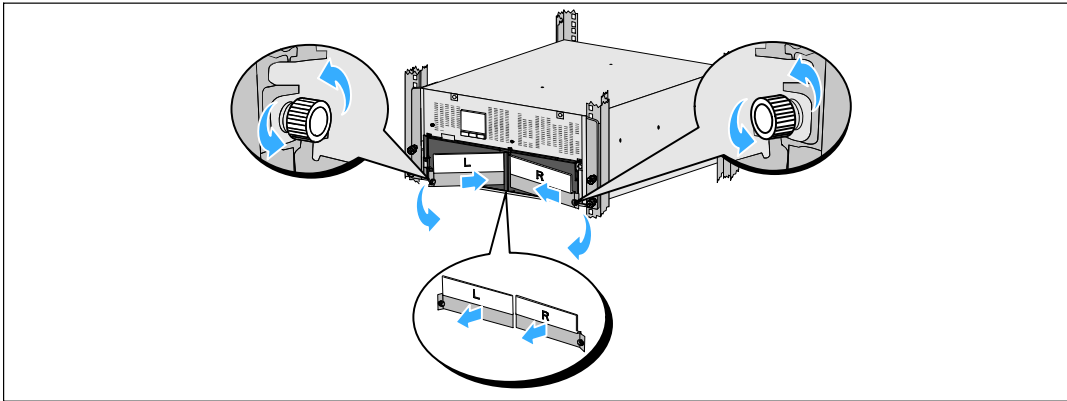

Figure 39. Removing the Battery Retaining Brackets

- 3 Disconnect the battery connectors (see Figure 40):

Locate the battery jumpers tucked into the small shelf at the top of the center post. Pull them off the shelf and disconnect them.

Locate and disconnect the remaining battery connectors for the left and right battery trays.

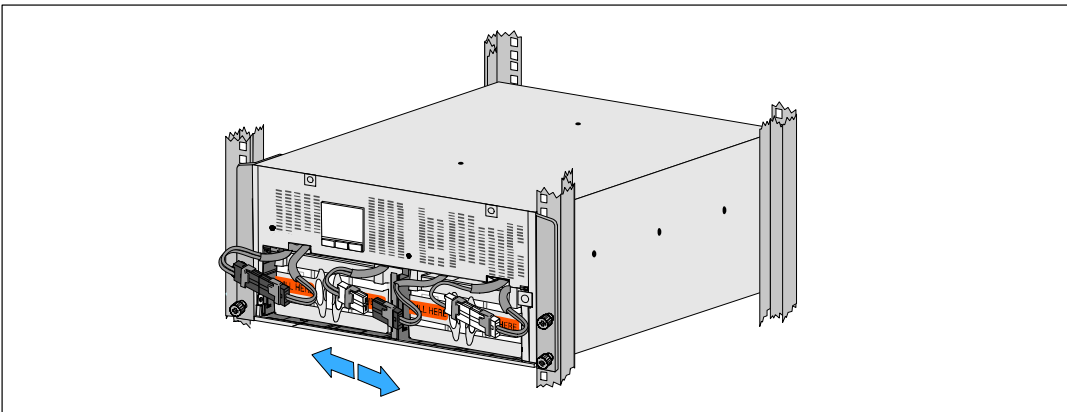

Figure 40. Disconnecting the Battery Connectors

⚠ CAUTION: The batteries are heavy (32 kg/71 lb). Use proper lifting techniques when removing used batteries and installing new batteries.

4 Remove the used battery trays from the UPS (see Figure 41):

Move the disconnected UPS battery connectors at the top of the battery compartment out of the way.

Grip the two plastic loop tabs on the front of the battery tray. Pull the tray toward you to remove.

✎ NOTE: The orange PULL HERE labels indicate where to grasp the loop tabs.

Repeat with the second battery tray.

⚠ CAUTION: Proper disposal of batteries is required. Refer to your local codes for disposal requirements.

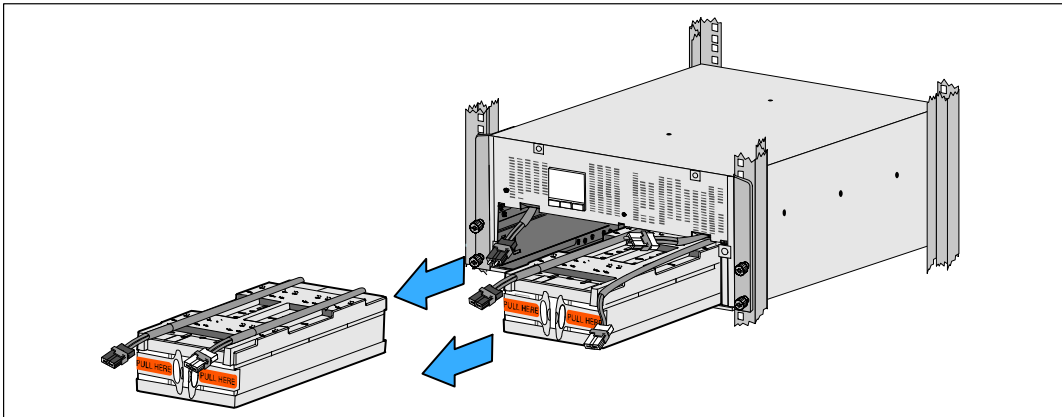

Figure 41. Removing the Battery Trays

✎ NOTE: The battery trays can be installed in either battery compartment.

✎ NOTE: Insert the tray with the caution label arrow pointing upward.

5 Install the new UPS battery trays (see Figure 42):

Move the disconnected UPS battery connectors at the top of the battery compartment out of the way.

Slide the battery tray into the battery compartment completely.

Repeat to install the second battery tray.

6 Tuck the loop tabs into the plastic sleeve on the front of each battery tray to move them out of the way.

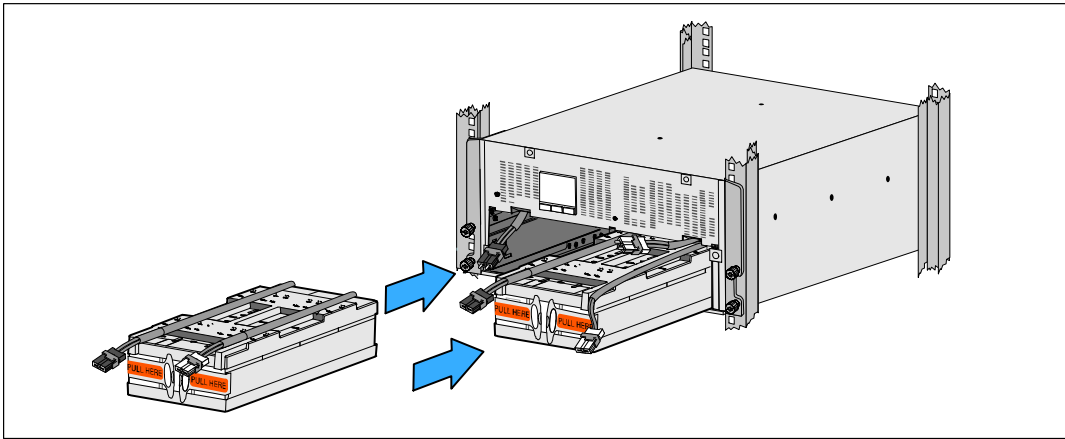



Figure 42. Installing the Battery Trays

- 7 Connect the internal battery connectors (see Figure 43):

Connect the left battery tray connector to the UPS battery connector. Connect the right battery tray connector to the UPS battery connector.

 **NOTE:** A small amount of arcing may occur when connecting the batteries. This is normal and does not damage the unit or present any safety concerns.

Locate and connect the battery jumpers located on either side of the center post. Place the connectors on the small shelf at the top of the center post.

 **NOTE:** Connecting the center battery jumpers connects the two battery trays serially.

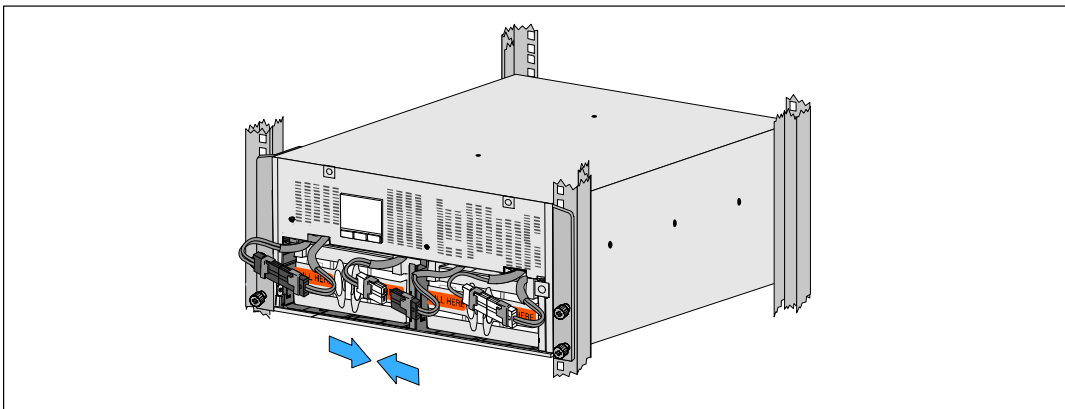

Figure 43. Connecting the Battery Connectors

NOTE: The battery retaining brackets are labeled L (Left) and R (Right) to indicate where they must be installed.

8 Replace the left (L) and right (R) battery retaining brackets (see Figure 44):

For the first battery retaining bracket, insert the bracket tab into the channel on the side of the center post. Fit the connected battery cables snugly behind the retaining bracket.

Align the end of the battery retaining bracket with the channel on the side of the chassis.

Push the bracket until it is firmly seated into the side channel.

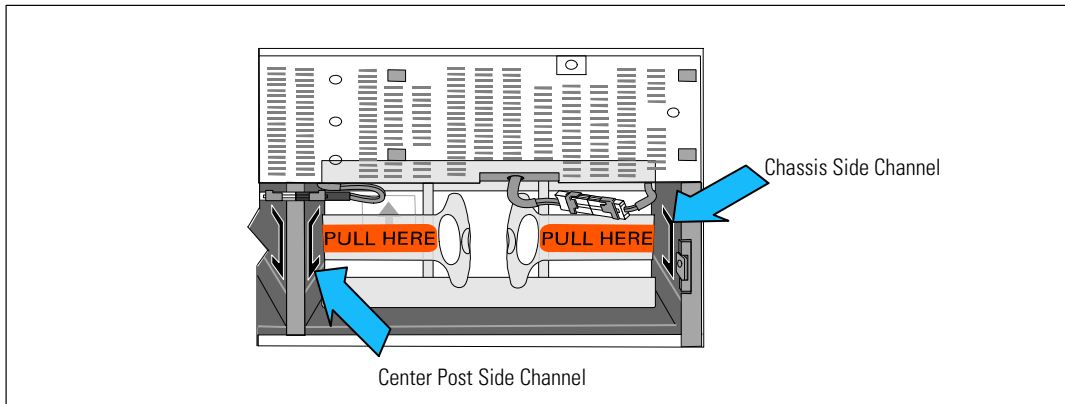

Figure 44. Inserting the bracket into the Channels

Turn the thumbscrew clockwise to secure the bracket.

Repeat to replace the second battery retaining bracket.

9 Replace the UPS front cover (see Figure 45).

Align the front cover with the front of the chassis.

Insert the right-side tabs on the front cover into the right-side chassis tab openings.

Push the left side of the cover forward and snap it to the chassis.



NOTE: Ensure that the LCD panel on the UPS chassis aligns with the LCD window on the front cover before securing the cover to the chassis.

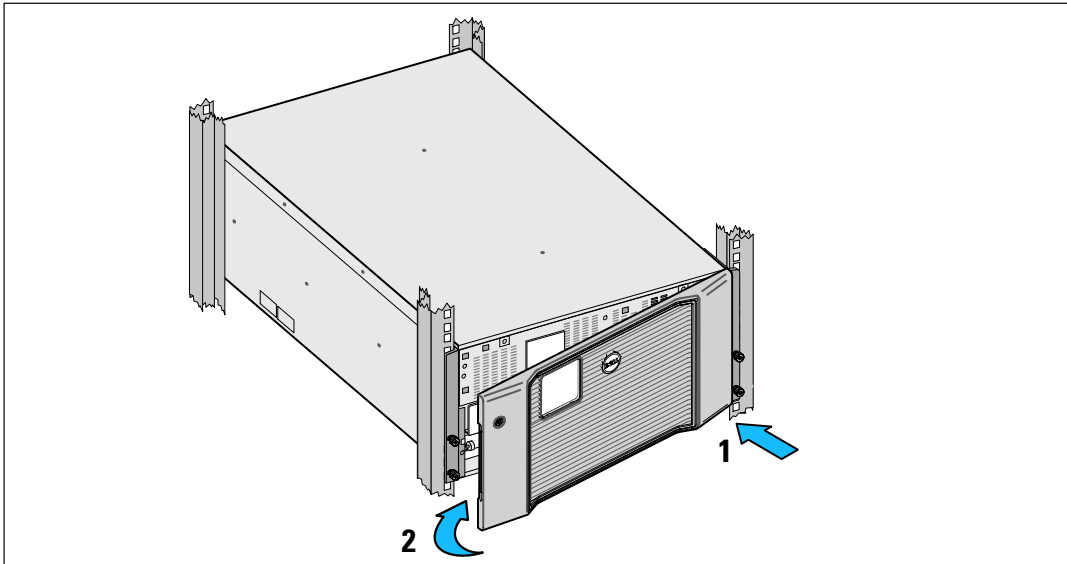

Figure 45. Replacing the UPS Front Cover

Testing Batteries

For a battery test to run:

- The batteries must be fully charged.
- The UPS must be in Normal mode with no active alarms.
- The load must be higher than 10%.

To test batteries:

- 1 Connect the UPS to utility power for at least 48 hours to charge the batteries.
- 2 Press the < button for one second to go to the main menu selection and scroll down to the Control menu using the > button.
- 3 Press the ✓ button to enter the Control menu.
- 4 Use the > button to scroll to the Battery Test option.
- 5 Press the ✓ button to start the battery test.

During the battery test, the UPS transfers to Battery mode and discharges the batteries for 25% of the original expected runtime. The status screen displays “Battery test running” and the percentage of the test completed. The results display on the UPS status screen when complete.

Updating the UPS Firmware

To keep the UPS firmware updated with the latest improvements and benefits, visit www.dellups.com for updates. You can download the latest firmware version and the instructions for installing it.

Specifications

This chapter provides the following specifications:

- Model list
- Dimensions and weights
- Electrical input and output
- Environmental and safety
- Battery
- UPS block diagram

 **NOTE:** All Dell 10 kW UPSs are designed for power factor corrected loads. Using systems with high crest factors will limit the available power to less than the UPS rating.

Table 11. UPS Model List

	208V Model	230V Model	230V Model
UPS Models	DELL10KWOLHVUS Dell Online Rack 10 kW North American and Japan	DELL10KWOLHV Dell Online Rack 10 kW International	DELL10KWOLHVB Dell Online Rack 10 kW International (Blades)
External Battery Module (EBM)	DELL10KWEBM, 288 Vdc/40A		

Table 12. Weights and Dimensions

	DELL10KWOLHVUS 208V Model and DELL10KWOLHVB 230V Model	DELL10KWOLHV 230V Model	EBM Model
Dimensions with Front Cover (W×H×D)	438.0×212.0×813.2 mm (17.2"×8.4"×32.0")	438.0×212.0×823.0 mm (17.2"×8.4"×32.4")	438.0×127.0×736.6 mm (17.2"×5.0"×29.0")
Rack Unit Size	5U		3U
Weights	99.0 kg (217.8 lb)		79.0 kg (173.8 lb)

Table 13. Electrical Input

	DELL10KWOLHVUS 208V Model	DELL10KWOLHV and DELL10KWOLHVB 230V Model
Nominal Voltage	208V	230V
Nominal Voltage Range	180–276V auto-sensing	
Nominal Frequency	50/60 Hz auto-sensing, ±3 Hz	
Efficiency	>96% (High Efficiency Mode) >94% (Normal Mode) >90% (Battery Mode)	
Noise Filtering	Full-time EMI/RFI filtering	
Connections	Hardwired	

Table 14. Electrical Output

	DELL10KWOLHVUS 208V Model	DELL10KWOLHV 230V Model	DELL10KWOLHVB 230V Model
Output Receptacles	(2) NEMA L6-30R, 30A (4) IEC 60320 C19, 20A	(2) IEC 60309 332R6S, 32A (2) IEC 60320 C19; 16A for IEC, 20A for UL	(8) IEC 60320 C19 (4 pairs/4 breakers); 16A for IEC, 20A for UL
Power Levels (Rated at Nominal Inputs)	10 kW		
Regulation (Normal Mode)	-6% to +6% of nominal voltage NOTE: Varies based on auto-detected input voltage or customer settings.		
Regulation (Battery Mode), Nominal Voltage ±5%	-6% to +6% of nominal voltage NOTE: Varies based on auto-detected input voltage or customer settings.		
Voltage Waveform	Sine wave		

Table 15. Environmental and Safety

	DELL10KWOLHVUS 208V Model	DELL10KWOLHV and DELL10KWOLHVB 230V Model
Safety Conformance	UL 1778 4th Edition; CSA C22.2, No. 107.3	UL 1778 4th Edition; CSA C22.2, No. 107.3; IEC/EN 62040-1; IEC/EN 60950-1
Safety Markings	UL, cUL, VCCI, NOM, BSMI, FCC	UL, cUL, CE, GS, GOST, BSMI, S-MARK, KC, NRCS, NOM, C-tick, CQC, FCC
EMC (Class A)	FCC Part 15, VCCI, BSMI	IEC/EN 62040-2; EN 55022/CISPR 22; CNS14757-2; AS/NZS 62040.2; FCC Part 15; KN22; GB7260.2; EN 55024/CISPR 24
Operating Temperature	0°C to 40°C (32°F to 104°F)	
Transit Temperature	-15°C to 60°C (5°F to 140°F)	
Extended Storage Temperature	-15°C to 45°C (5°F to 113°F)	
Relative Humidity	0–95% noncondensing	
Operating Altitude	Up to 3048 meters (0–10,000 ft)	
Storage Elevation	Up to 15240 meters (0–50,000 ft)	
Audible Noise	Less than 55 dBA on line/bypass mode (less than 75% load), room temperature	
Surge Suppression	ANSI/IEEE C62.41; 1991 Category B3	

Table 16. Battery

Configuration	10 kW: (24) 288V, 9.0 Ah internal batteries; EBM: (24) 288V, 9.0 Ah
Battery Type	YUASA NPW 45-12 9.0 Ah
Voltage	10 kW: 288 Vdc internal; EBM : 288 Vdc/40A
Fuses	UPS: (1) 80A fuses EBM: (1) 80A fuses
Type	Sealed, maintenance-free, valve-regulated, lead-acid
Charging	10 kW internal batteries: Approximately 4 hours to 90% usable capacity at nominal line and no supplementary power supply load EBM: Approximately 8 hours to 90% usable capacity at nominal line and no supplementary power supply load
Monitoring	Advanced monitoring for earlier failure detection and warning
Battery Runtimes*	10 kW internal batteries: 5 minutes at full load/14 minutes at half load 10 kW with one EBM attached: 13 minutes at full load/35 minutes at half load

* Battery runtimes are approximate and vary depending on the load configuration and battery charge.

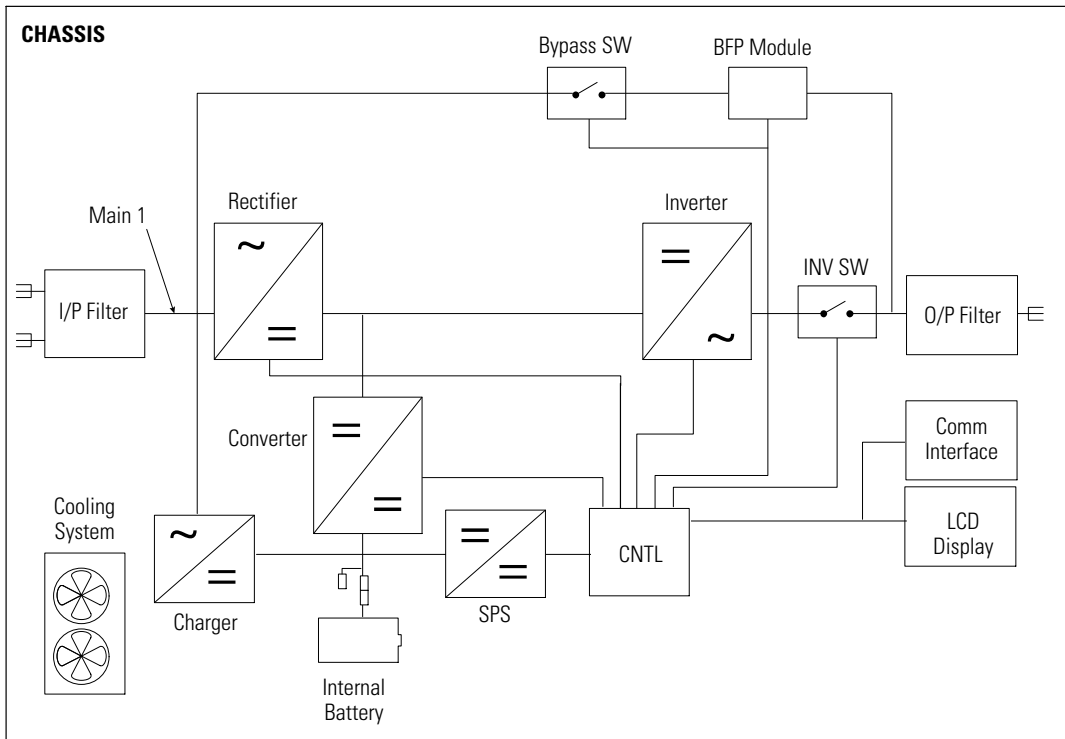

Figure 46. Online UPS Block Diagram

Troubleshooting

The Dell Online Rack UPS is designed for durable, automatic operation and issues alarms to alert you whenever potential operating problems occur. Usually the alarms shown by the control panel do not mean that the output power is affected. Instead, they are preventive alarms intended to alert the user. Active alarms and active notices are accompanied by an audible buzzer.

Accessing Alarms and Conditions

The control panel provides troubleshooting information from two main menus:

- **UPS status menu:** Access to all active alarms
- **Event Log menu:** Access to the most recent 50 events, which may include active and closed alarms

UPS Status Menu

From the UPS Status menu, you can access the following screens for troubleshooting information:

- **Status summary screen:** The status summary screen provides information on both mode and load. When there is a critical alarm, the status summary screen changes from its normal white text on a blue background to dark amber text on an amber background.
- **Notice or alarm screens:** A separate screen appears for each active notice or alarm. If there are no active alarms or notices, the display reads “No Active Alarms.”
- **Battery status screen:** The battery status screen indicates the battery charge mode, the percent the battery is charged, and the runtime with the present load level.



NOTE: When an alarm is active, the control panel automatically displays an active alarm screen unless the screen lock is enabled by the user.

To access troubleshooting information using the UPS status menu screen:

- 1 Press the **<** button for one second or longer to go to the UPS status menu screen.
- 2 Press the **✓** button to access the UPS Status Summary screen.
- 3 Press the **>** button to access the notice and alarm screens.

The UPS Status Summary screen provides load information. The status icon indicates the UPS operating mode (see Table 4 on page 42).

- 4 Use the **>** button to scroll through the notice and alarm screens.
- 5 After scrolling through all alarms, press the **>** button to access the battery status screen.

Event Log Menu

From the Event Log menu, you can access the last 50 events, which includes events, notices, and alarms, arranged from newest to oldest. Events, notices, and alarms are logged in the Event Log when they occur and, if applicable, when they were cleared as follows:

- Events are silent conditions that are recorded in the Event Log as status information, such as “Clock Set Done.” Events do not require a response.
- Notices, including active notices, are recorded in the Event Log. Active notices, such as “Bypass AC Over Voltage,” are typically announced by an intermittent beep. Notices do not normally require a response.
- Alarms, including active alarms, are recorded in the Event Log. Active alarms are typically announced by either an intermittent beep or a continuous audible alarm. Examples are “Fan Failure” and “Heatsink Over Temperature.” Active alarms require a response.

The UPS Status menu displays by default. To access troubleshooting information using the Event Log menu:

- 1 Press the < button for one second to go to the main menu selection and scroll down to the Event Log menu using the > button.
- 2 Click the ✓ button to enter the Event Log list.
- 3 Scroll through the listed events, notices, and alarms using the > or < button.

Alarms, Notices, and Events

Table 17 describes typical alarms, notices, and events.

Table 17. Alarms, Notices, and Events

Alarms, Notices, and Events	Possible Cause	Action
The UPS does not provide or indicate the expected backup time.	The batteries need charging or service.	Apply utility power for 48 hours to charge the batteries. If the condition persists, contact your service representative.
Power is not available at the UPS output receptacles.	The UPS is in Standby mode.	Supply power to the connected equipment by pressing the On/Off button until the front panel displays the UPS status summary screen.
The UPS does not start. (The LCD is off.)	Power is not connected.	Check the power connections. Also ensure that the battery is connected to utility power.
The UPS operates normally, but some or all of the protected equipment is not on.	The equipment is not connected correctly to the UPS.	Verify that the equipment is plugged into the UPS receptacles. Also verify that the load segment is on.

Table 17. Alarms, Notices, and Events

Alarms, Notices, and Events	Possible Cause	Action
Battery test did not run or was interrupted.	One of the conditions listed in “Running Automatic Battery Tests” on page 61 was not present.	Resolve the condition, then restart the test.
The UPS does not transfer to Bypass mode.	The bypass utility does not qualify.	Check the bypass utility. The UPS is receiving bypass utility power that may be unstable or in brownout conditions.
	Bypass mode is disabled.	Check that the Bypass settings are configured correctly. See “Settings” on page 48.
UPS on Bypass (Notice 169) Intermittent Alarm	The UPS is operating from Bypass mode.	The equipment transferred to bypass utility power. Battery mode is not available and your equipment is not protected; however, the utility power continues to be passively filtered by the UPS. Check for one of the following alarms: overtemperature, overload, or UPS failure.
On Manual Bypass (Notice 143) Intermittent Alarm	UPS was manually commanded to transfer to Bypass mode and will remain in bypass until commanded.	None.
Battery Disconnected (Alarm 199) Beeping Alarm	The UPS does not recognize the internal batteries.	If the condition persists, contact your service representative.
	Battery voltage is lower than the batteries disconnected level defined for this UPS. This may be due to a blown fuse, intermittent battery connection, or battery cable being disconnected.	Verify that all batteries are properly connected. If the condition persists, contact your service representative.
Low Battery Warning (Alarm 56) Beeping Alarm	Battery time remaining or battery capacity is lower than the battery low warning level defined for this UPS.	This warning is approximate. The actual time to shutdown may vary depending on the UPS load and presence of an External Battery Module (EBM).
Low Battery Shutdown (Alarm 174) Continuous Alarm	The UPS has exhausted the battery capacity and shut down.	Resolve the condition that led to shutdown, and then apply utility power for 48 hours to recharge the batteries.

Table 17. Alarms, Notices, and Events

Alarms, Notices, and Events	Possible Cause	Action
Shutdown Imminent (Alarm 55) Continuous Alarm	Communication to external devices stops because the UPS has entered a state where it may abruptly stop operating without further notice unless utility returns.	The alarm is issued when the battery time remaining reaches zero. All connected devices should have already shut down gracefully.
Battery Test Failed (Notice 191) Intermittent Alarm	A weak battery string was detected during the last battery test.	This is a warning notice. Dell recommends that you replace the batteries soon.
Service Battery (Alarm 149) Beeping Alarm	A faulted battery string has been detected and as a result, the charger is disabled.	Contact your service representative.
Utility Not Present (Notice 59) Intermittent Alarm	The utility level has fallen below the Utility Not Present threshold (typically <25 to 50V).	Transfer to battery if supporting load. Power down if not supporting load.
Bypass Not Available (Event 105) No Alarm	The utility is outside of the bypass limits defined in the UPS.	Check the bypass settings. See “Settings” on page 48.
Input AC Over Voltage (Alarm 6) Beeping Alarm	The utility voltage exceeds the maximum operating range.	The UPS transfers to Battery mode if supporting load.
Input AC Under Voltage (Notice 7) Intermittent Alarm	The utility voltage is below the minimum operating range.	The UPS transfers to Battery mode if supporting load.
Input Under/Over Frequency (Notice 8) Intermittent Alarm	The utility frequency is out of usable frequency range.	The UPS transfers to Battery mode if supporting load.
Site Wiring Problem (Alarm 194) Beeping Alarm	An alarm triggers when the difference between ground and neutral voltage is >15V.	Have a qualified electrician correct the wiring problem. If the UPS is not wired with a neutral wire, Site Fault should be disabled in the Settings menu (see page 48).

Table 17. Alarms, Notices, and Events

Alarms, Notices, and Events	Possible Cause	Action
Remote Emergency Power Off (Notice 12) Beeping Alarm	The external contacts in the rear of the UPS are configured for REPO operation and they have been activated.	The UPS de-energizes the load and enters Standby mode. See “Installing Remote Emergency Power-off” on page 26 for more information.
Output Overload (Alarm 25) Intermittent Alarm	The load level is at or has exceeded the configurable threshold limit for a Level 1 Overload condition.	The UPS can support the load indefinitely at this load level. The alarm clears when the load drops below 5% of the set point.
Output Overload Level 2 (Alarm 159) Beeping Alarm	The load level is >101% and <110% of the UPS rating.	Remove some of the equipment from the UPS. The UPS continues to operate, but transfers to Fault mode in two minutes. The alarm clears when the load drops below 5% of the set point.
Output Overload Level 3 (Alarm 162) Beeping Alarm	The load is >110% of the UPS rating.	Remove some of the equipment from the UPS. The UPS continues to operate, but transfers to Fault mode in 300 ms to one second. The alarm clears when the load drops below 5% of the set point.
Battery DC Over Voltage (Alarm 68) Beeping Alarm	Battery voltage levels have exceeded the maximum allowable limits.	The UPS turns off the charger until the next power recycle. Contact your service representative.
Charger Failure (Alarm 34) Continuous Alarm	A battery charger fault has been detected.	The UPS turns off the charger until the next power recycle. Contact your service representative.
Inverter AC Over Voltage (Alarm 0) Beeping Alarm	The UPS has detected abnormally high output voltage levels.	The UPS transfers to Bypass mode if supporting the load.
Inverter AC Under Voltage (Alarm 1) Beeping Alarm	The UPS has detected abnormally low output voltage levels.	The UPS transfers to Bypass mode if supporting the load.

Table 17. Alarms, Notices, and Events

Alarms, Notices, and Events	Possible Cause	Action
Bypass AC Over Voltage (Notice 3) Intermittent Alarm	The measured voltage on Bypass has exceeded the upper voltage limit specification for bypass operation.	A notification alarm is generated and the notice is logged. Only apply this setting when Qualify Bypass is set to Always and utility is present, but above the bypass overvoltage range. Do not apply this setting if a Utility Not Present alarm is active.
Bypass AC Under Voltage (Notice 4) Intermittent Alarm	The measured voltage on Bypass is less than the upper voltage limit specification for bypass operation.	A notification alarm is generated and the notice is logged. Only apply this setting when Qualify Bypass is set to Always and utility is present, but below the bypass undervoltage range. Do not apply this setting if a Utility Not Present alarm is active.
Bypass Under/Over Freq (Notice 5) Intermittent Alarm	The measured voltage on Bypass is out-of-range for either the upper or lower voltage limit specification for bypass operation.	A notification alarm is generated and the notice is logged. Only apply this setting when Qualify Bypass is set to Always and utility is present, but outside the bypass frequency range. Do not apply this setting if a Utility Not Present alarm is active.
Rectifier Input Over Current (Alarm 26) Beeping Alarm	The UPS has detected that rectifier input current limits have been exceeded.	The UPS transfers to Battery mode if supporting the load.
Inverter Output Over Current (Alarm 27) Beeping Alarm	The UPS has detected that the inverter output current limits have been exceeded.	The UPS transfers to Bypass mode if supporting the load.
DC Link Over Voltage (Alarm 28) Beeping Alarm	The link or rail voltage has exceeded its upper threshold limit.	The UPS transfers to Battery mode if supporting the load.
DC Link Under Voltage (Alarm 29) Beeping Alarm	The link or rail voltage has dropped below its lower threshold limit.	The UPS transfers to Battery mode if supporting the load.

Table 17. Alarms, Notices, and Events

Alarms, Notices, and Events	Possible Cause	Action
DC Link Imbalance (Alarm 1234) Beeping Alarm	The internal \pm DC bus (DC rail) voltages generated in the UPS are imbalanced.	The UPS transfers to Battery mode if supporting the load.
Rectifier Fault (Alarm 30) Continuous Alarm	The UPS has detected a fault in the rectifier circuit while attempting recovery from Bypass mode or Converter mode.	Contact your service representative.
Inverter Fault (Alarm 31) Continuous Alarm	The UPS has detected a fault in the inverter circuit while attempting a recovery from Bypass mode or Converter mode.	Contact your service representative.
Heatsink Over Temperature (Alarm 73) Beeping Alarm	The UPS has detected that one of its heat sinks has exceeded the maximum defined operating temperature. Possible fan failure.	The UPS transfers to Bypass mode if available. If the bypass is not available or the UPS is in power on or standby mode, the UPS transfers to fault mode. Ensure that the fans are spinning and that the air intake vents on the UPS are not blocked. Once the maximum temperature is reached, the UPS shuts down.
Fatal EEPROM Fault (Alarm 53) Continuous Alarm	There is EEPROM data corruption due to a failed device or incorrect flash upgrade.	Contact your service representative.
Output Short Circuit (Alarm 58) Beeping Alarm	The UPS has detected an abnormally low impedance placed on its output and considers it a short circuit.	If the UPS is in Normal mode, the UPS transfers to Bypass mode if available, otherwise, the UPS shuts down after three to five line cycles. If the UPS is in Battery mode, the UPS shuts down after three to five line cycles.
Fan Failure (Alarm 193) Continuous Alarm	The UPS has detected that one or more fans are not functioning properly.	This is an alarm only. Contact your service representative immediately and remove the load.
In High Efficiency Mode (Event 227) No Alarm	The UPS is operating in High Efficiency Mode.	None.

Table 17. Alarms, Notices, and Events

Alarms, Notices, and Events	Possible Cause	Action
UPS on Battery (Event 168) No Alarm	The UPS is operating from batteries (Battery mode).	None.
UPS Off (Event 170) No Alarm	The UPS is not operating (Standby or Fault mode).	None.
ABM State Charging (Event 1600) No Alarm	The status of ABM charge mode is constant current charging.	None.
ABM State Floating (Event 1601) No Alarm	The status of ABM charge mode is floating.	None.
ABM State Resting (Event 1602) No Alarm	The status of ABM charge mode is resting.	None.
ABM State Off (Event 1603) No Alarm	The status of ABM charge mode is Off or disabled.	None.
Clock Set Done (Event 1999) No Alarm	The UPS real-time clock setting has been adjusted. This can be initiated from the LCD or from the NMC card.	None.
To Bypass Command (Event 94) No Alarm	A request to transfer to Manual Bypass Mode was received from the software.	None.
From Bypass Command (Event 95) No Alarm	A request to transfer to Online Mode was received from the software.	None.

Table 17. Alarms, Notices, and Events

Alarms, Notices, and Events	Possible Cause	Action
UPS On Command (Event 172) No Alarm	A remotely issued UPS start up command (On command) was received from the software. It indicates a manually requested transition from Standby to Online mode. This event is not triggered for auto restarts.	None.
UPS Off Command (Event 173) No Alarm	A remotely issued UPS shutdown command (Off command) was received from remote software. It causes the UPS to open all output relays and shed the load.	None.
UPS Control Power On (Event 181) No Alarm	The UPS processor powered up, either from battery or utility power (in Standby or Online mode).	None.
UPS System Normal (Event 237) No Alarm	The UPS is in a normal mode of operation and no alarms are active.	None.

Silencing the Alarm

Press any button on the control panel to silence the alarm. Check the alarm condition and perform the applicable action to resolve the condition. If any new alarm becomes active, the audible alarm resumes, overriding the previously silenced alarm.